

FINE AND RARE WINES

FEATURING EXCEPTIONAL
PRIVATE COLLECTIONS

佳士得名釀

Hong Kong, 26 November 2016 | 香港 2016 年 11 月 26 日



CHRISTIE'S 佳士得

INTERNATIONAL WINE DEPARTMENT & AUCTION CALENDAR

INTERNATIONAL

HEAD OF DEPARTMENT

David Elswood
Tel: +44 (0)20 7752 3366

HEAD OF DEPARTMENT

ASIA

Simon Tam
Tel: +852 2978 6765

LONDON

Chris Munro
Tel: +44 (0)20 7752 3140

NORTH AMERICA

Per Holmberg
Tel: +1 212 484 4841

SENIOR CONSULTANTS

Michael Broadbent M.W.
Anthony Hanson M.W.
Tel: +44 (0)20 7752 3314

WORLDWIDE

AMSTERDAM

Edwin Vos
Tel: +31 (0)20 575 5208

BELGIUM

Fiona Morrison, M.W.
Tel: +32 (0)55 31 17 59

BORDEAUX

Bill Blatch
Tel: +33 (0)777 965 565

BEIJING

Austin Zhang
Tel: +86 10 8572 7927

GENEVA

Agathe de Saint Céran
Tel: +41(0) 22 31 917 60

HONG KONG

Simon Tam
Tim Triptree
Fai Lo
Tiffany Po
Tel: +852 2978 6761

LONDON

Carolyn Holmes
Peter Mansell
Charles Foley
Duncan McEuen (Consultant)
Tel: +44 (0)20 7752 3302

LOS ANGELES

Scott Torrence
Tel: +1 310 385 2625

NEW YORK

Per Holmberg
Richard Young
Noah May
Layla Khabiri
Scott Torrence
Tel: +1 212 636 2270

PARIS

Edwin Vos
Agathe de Saint Céran
Clément Huvet
Tel: + 33(0) 1 40 76 83 88

BUSINESS MANAGERS

FRANCE

Sarah de Maistre
Tel: +33 (0)1 40 76 83 56

HONG KONG

Cindy Tse
Tel: +852 2978 6759

LONDON

Laure Camboulives
Tel: +44 (0)20 7752 3252

NEW YORK

Devon Elovitz
(Business Coordinator)
Tel: +1 212 641 5776

10/08/16

AUCTION CALENDAR 2016

To include your property in these sales please consign ten weeks before the sale date. Contact the specialists or representative office for further information.

10 NOVEMBER

FINE AND RARE WINES
LONDON, KING STREET

13 NOVEMBER

FINE WINES
GENEVA

17 NOVEMBER -

1 DECEMBER
WINE ONLINE/LDN

20 NOVEMBER

156ÈME VENTE DES VINS
DES HOSPICES DE BEAUNE
BEAUNE

25-26 NOVEMBER

FINE AND RARE WINES:
A GENTLEMAN'S
COLLECTION
HONG KONG

26 NOVEMBER

FINE AND RARE WINES
FEATURING EXCEPTIONAL
PRIVATE COLLECTIONS
HONG KONG

8 DECEMBER

FINE AND RARE WINES
LONDON, KING STREET

9 DECEMBER

FINE AND RARE WINES
NEW YORK

SERVICES · 服務

WRITTEN AND TELEPHONE BIDS

書面和電話競投

Tel 電話：+852 2978 9910

Email 電郵：bidsasia@christies.com

PADDLE REGISTRATION & CHRISTIE'S LIVE

競投牌登記和佳士得實時競投服務

Tel 電話：+852 2760 1766

Email 電郵：registrationasia@christies.com

CATALOGUES ONLINE 網上拍賣目錄

Lotfinder®

Internet 網站：www.christies.com

CLIENT SERVICES 客戶服務

Tel 電話：+852 2760 1766

Email 電郵：infoasia@christies.com

POST-SALE SERVICES 售後服務

Tel 電話：+852 2760 1766

Fax 傳真：+852 2973 0111

Email 電郵：postsaleasia@christies.com

AUCTION RESULTS 拍賣結果

HK 香港：+852 2760 1766

UK 英國：+44 (0)20 7627 2707

US 美國：+1 212 703 8080

Internet 網站：www.christies.com

We have re-located our wine storage facility to Crown Wine Cellars, 2/F Crown Data Centre 1, 6 Kin Fung Circuit, Tuen Mun, N.T. Wines purchased in this sale, will be available for collection and/or delivery from Crown Wine Cellars. For further details, please contact Post-Sale Services Department on +852 2760 1766.

本公司已將名酒儲存庫搬遷至 Crown Wine Cellars (新界屯門建豐街6號嘉柏中心1期2樓)。此次名酒拍賣的名酒可於 Crown Wine Cellars 提取和/或交付。請聯繫佳士得售後服務部 (電話+852 2760 1766) 查詢詳情。

Scan to view auction details

掃描以瀏覽拍賣詳情



Christie's Hong Kong Autumn Auctions Microsite
佳士得香港秋拍週網站

CHRISTIE'S LIVE
Bid live in Christie's salerooms worldwide

christies.com

FINE AND RARE WINES

FEATURING EXCEPTIONAL PRIVATE COLLECTIONS

佳士得名釀

SATURDAY 26 NOVEMBER 2016 · 2016年11月26日 (星期六)

AUCTION · 拍賣

Saturday 26 November · 11月26日 (星期六)

1.00pm (Lots 6001-6494) · 下午1.00 (拍賣品編號6001-6494)

Location: Grand Hall, Hong Kong Convention and Exhibition Centre,

No.1 Expo Drive, Wanchai, Hong Kong

地點：香港灣仔博覽道1號香港會議展覽中心大會堂

Tel 電話：+852 2760 1766 · Fax 傳真：+852 2760 1767

AUCTION CODE AND NUMBER · 拍賣名稱及編號

In sending Written and Telephone bids or making enquiries, this sale should be referred to as **VERTICAL-12577**

在遞交書面和電話競投表格或查詢拍賣詳情時，請註明拍賣名稱及編號為 **VERTICAL-12577**。

CONDITIONS OF SALE · BUYING AT CHRISTIE'S

業務規定 · 買家須知

This auction is subject to Important Notices and Explanation of Cataloguing Practice, Conditions of Sale · Buying at Christie's and reserves of the lots.

此次拍賣受限於重要通知及目錄編列方法之說明、業務規定 · 買方須知及拍品底價。

ENQUIRIES · 查詢

Jennifer Lo, Sale Co-ordinator 盧正琛

Tel 電話：+852 2978 6761

EMAIL · 電郵

For general enquiries about this auction, emails should be addressed to the Sale Co-ordinator(s) at wineauction@christies.com

如對此拍賣有任何查詢，可與佳士得拍賣統籌聯絡。

電郵地址：wineauction@christies.com

AUCTIONEERS · 拍賣官

David Elswood

Simon Tam

Austin Zhang

CHRISTIE'S 佳士得

INTERNATIONAL WINE DEPARTMENT

SENIOR INTERNATIONAL TEAM



David Elswood



Per Holmberg



Chris Munro



Edwin Vos

ASIA TEAM



Simon Tam



Tim Triptree



Fai Lo



Tiffany Po



Austin Zhang



Cindy Tse

INTERNATIONAL CONSULTANTS



Michael Broadbent
M.W.



Anthony Hanson
M.W.



Bill Blatch

FINE AND RARE WINES

FEATURING EXCEPTIONAL
PRIVATE COLLECTIONS

佳士得名釀

SATURDAY 26 NOVEMBER 2016

1.00pm

Lots 6001-6494

Sale 12577

11月26日(星期六)

下午一時正

(拍品 6001 至 6494)

編號 12577

Grand Hall, Hong Kong Convention and Exhibition Centre,
No.1 Expo Drive, Wanchai, Hong Kong
香港灣仔博覽道1號香港會議展覽中心大會堂

Please note that parcel bidding will be offered throughout Sale 12577.

請注意，本場拍賣（編號 12577）部份拍品將以組合形式推出。成功投得每個組合第一款拍品的買家，可選擇以同一價格購買餘下所有或部份拍品。

Christie's Hong Kong Wine Department is delighted to be offering some exceptionally rare wines in our autumn 2016 sale season. I write this with more than just a hint of sadness as this will be my final sale of my secondment in Hong Kong before returning to Christie's in London. It has been a wonderful four years working in Hong Kong alongside the fantastic Christie's Hong Kong Wine Department and getting to know you, our Christie's clients. In this time I have worked on some spectacular sales such as the Henry Tang Collection, Sir Alex Ferguson CBE, Direct from Great Estates and most recently from Domaine Bouchard Père & Fils. I have been fortunate to welcome to Hong Kong many esteemed wine producers; Philippe Guigal, Gilles de Larouzière from Bouchard, Axel Heinz from Masseto to name just a few and have enjoyed many memorable fine wine dinners and tastings. Another highlight has been the people I have met in Hong Kong and Asia; my lasting impression will be their warmth and generosity, and of course sharing their vinous treasures with me!

This sale features a number of single-owner collections including a collection of the very best from Champagne, Bordeaux & Burgundy, an impressive selection of Classed Growth Bordeaux coming direct from Bordeaux City Bond and a private collection of Finest & Rarest Bordeaux & Burgundy. Also offered are rare Vertical Collections of Latour & Mouton Rothschild. We are delighted once again to be raising funds for the 2016 Decanter Asia Wine Scholarship Programme.

Please do not hesitate to contact the Hong Kong wine team for advice and best of luck with your bids!

I look forward to welcoming you to the Christie's saleroom in London.

Tim Triptree

Head of Hong Kong Sales, Wine

佳士得香港名酒部將於 2016 年秋季拍賣隆重呈獻多款珍稀佳釀；而這將是本人返回佳士得倫敦前負責的最後一場拍賣，著實帶點不捨。在香港工作的四年間，我與佳士得香港名酒部度過了無數美好時光，亦有幸結識你們，親愛的佳士得客戶。數年來，我參與過多場精采拍賣，包括「唐英年窖藏珍釀」、「亞歷山大·費格遜爵士 CBE 窖藏珍罕名釀」、「顯赫名窖直遞珍釀」，以及早前舉行的「寶尚父子酒莊歷史窖藏」。我很榮幸能在香港親自款待一眾知名釀酒師，如寶尚的菲利普·吉佳樂 (Philippe Guigal) 和吉利斯·拉若澤維爾 (Gilles de Larouzière) 以及馬賽托的阿克塞爾·亨氏 (Axel Heinz)，並多次出席美酒晚宴和品酒會，令我回味萬分。在香港和亞洲遇見的人物同樣令我十分難忘，大家的熱情和慷慨在我心中留下深刻印象，我亦很開心能與大家分享不同珍釀！

是次拍賣網羅多個單一藏家珍藏，包括卓爾不凡的香檳、波爾多和勃艮第珍藏、直接取自波爾多貯存倉庫 (Bordeaux City Bond) 的特級波爾多精選系列，以及波爾多及勃艮第極品稀世私人珍藏。另帶來拉圖和木桐的罕見垂直系列。在 2016 年，我們很高興再度透過拍賣活動為 Decanter 亞洲葡萄酒獎學金計劃 (Decanter Asia Wine Scholarship Programme) 籌集資金。

請即與香港名酒部聯絡，讓我們為您提供專業建議。祝君好運，順利投得心儀佳釀！

我期待在佳士得倫敦拍賣廳與您再次會面。

鄧卓謙

香港名酒部拍賣主管

SATURDAY 26 NOVEMBER 2016

1.00PM · Lots 6001-6494

FINE AND RARE WINES

FEATURING EXCEPTIONAL PRIVATE COLLECTIONS

佳士得名釀

FINEST & RAREST CHAMPAGNE, BORDEAUX, BURGUNDY & RHONE FROM AN EXCEPTIONAL PRIVATE COLLECTION

We are privileged to be able to offer the following lots 6001 to 6074 which are part of a superb private collection of many of the finest wines from Champagne, Bordeaux, Burgundy and the Rhône.

The collection encompasses superlative vintages of Dom Pérignon, Krug and Cristal which will be ideal for that special celebration.

From Bordeaux the finest wines from the most prestigious producers; from the Left Bank; Latour, Mouton Rothschild, Haut-Brion; and from the Right Bank, Lafleur, Petrus, and Cheval Blanc.

From Burgundy are included highly sought-after wines from the finest Domaines including Armand Rousseau, de Vogüé, Domaine de la Romanée-Conti, Henri Jaye, Domaine Leroy, Méo-Camuzet, J.F. Mugnier, Ponsot, G. Roumier and Coche-Dury.

J.L. Chave's extremely rare Ermitage Cuvée Cathelin completes this fine collection.

The wines were stored in a professional temperature and humidity controlled wine storage facility in Hong Kong. The cellar temperature is strictly maintained at 14°C to 16°C and 60% to 70% relative humidity. The wines were inspected in situ and once again in our Hong Kong storage warehouse by Christie's Specialists.

精品私人珍藏香檳、波爾多、勃艮第和羅納河谷

我們很榮幸推出編號 6001-6074 的收藏，該精品私人珍藏涵蓋香檳、波爾多、勃艮第和羅納河谷最多佳釀。

其中的傑出年份的唐培裡儂、庫克和水晶香檳將是您慶祝時刻的不二選擇。

收藏同樣涵蓋了波爾多的頂級酒莊，例如左岸的拉圖、木桐和侯伯王，右岸的花堡、柏翠和白馬。

勃艮第產區的精品酒莊同樣令人垂涎。盧梭、梧玖、羅曼尼康帝、亨瑞賈耶、樂華、梅歐卡慕則、穆尼埃、彭壽、胡米耶和寇詩杜裡等。

本收藏最令人心動的，莫過於夏夫難得一見的艾米塔吉產區卡特琳珍藏。

所有普天就均貯藏於香港專業的控溫控濕酒窖。酒窖溫度嚴格控制在 14-16 攝氏度；濕度在 60-70%。佳士得專家在現場進行了檢查，並且在運輸到佳士得香港葡萄酒倉庫後進行了複查。

Dom Pérignon Rosé 1985

Epernay

US import slip label. Level 1.5cms

6001 1 magnum *per lot* HK\$11,000-16,000

Krug Collection 1979

Reims

In individual wooden cases. Two detached vintage neck labels

6002 3 magnums *per lot* HK\$80,000-120,000

Krug Clos du Mesnil 1995

Reims

In individual original wooden cases

6003 3 bottles *per lot* HK\$18,000-24,000



Krug 1995*Reims**In original carton*6004 6 bottles *per lot* HK\$10,000-15,000**Louis Roederer, Cristal Brut 1999***Reims**Very slightly damaged neck label. Japanese import slip label*6005 1 jeroboam *per lot* HK\$10,000-14,000**Louis Roederer, Cristal Rosé Brut 2000***Champagne**In original individual wooden cases. Japanese import back labels*6006 2 magnums *per lot* HK\$14,000-20,000**Louis Roederer, Cristal Rosé Brut 1989***Champagne**Integrated US import slip labels*6007 6 bottles *per lot* HK\$30,000-45,000**Veuvre Clicquot Rosé 1985***Champagne**In original carton*6008 6 bottles *per lot* HK\$5,000-7,500**Château Latour 1970***Pauillac, 1er cru classé**One very slightly damaged capsule. US import slip labels. Very slightly stained and one very slightly damaged labels. Levels top-shoulder*6009 3 bottles *per lot* HK\$10,000-15,000**Château Latour 2006***Pauillac, 1er cru classé**In individual wooden cases. US import back labels. Levels into neck*6010 3 magnums *per lot* HK\$15,000-26,000**Château Mouton Rothschild 2000***Pauillac, 1er cru classé**In original wooden case*6011 12 bottles *per lot* HK\$110,000-160,000**Château Mouton Rothschild 2003***Pauillac, 1er cru classé**US import slip labels*6012 6 magnums *per lot* HK\$30,000-45,000**Château Mouton Rothschild 2003***Pauillac, 1er cru classé**In original wooden case*6013 12 bottles *per lot* HK\$30,000-45,000**Château Mouton Rothschild 2005***Pauillac, 1er cru classé**In banded original wooden case*6014 12 bottles *per lot* HK\$38,000-55,000**Château Haut-Brion 1975***Pessac (Graves), 1er cru classé**In original wooden case. Eight very slightly stained labels. US import slip labels. Levels one 1.5cms, six 2cms, three 2.5cms, one 3cms and one 3.5cms*6015 12 bottles *per lot* HK\$32,000-48,000**Château Haut-Brion 2005***Pessac (Graves), 1er cru classé**In original wooden case*6016 12 bottles *per lot* HK\$55,000-80,000**Château Haut-Brion 2008***Pessac (Graves), 1er cru classé**In original wooden case with replacement lid. US import slip labels*6017 12 bottles *per lot* HK\$24,000-35,000

Petrus 1978*Pomerol, cru exceptionnel**Two slightly damaged capsules. Two stained and one slightly damaged integrated US import labels. Levels one top-shoulder and two upper-shoulder*6018 3 bottles *per lot* HK\$22,000-30,000**Petrus 1982***Pomerol, cru exceptionnel**One very slightly damaged capsule. US import slip labels. Levels into neck*6019 3 bottles *per lot* HK\$60,000-110,000**Petrus 1988***Pomerol, cru exceptionnel**In original wooden case. One sign of old seepage. Badly stained integrated US import labels. Levels one into neck and two base of neck*6020 3 double-magnums *per lot* HK\$200,000-300,000**Petrus 1995***Pomerol, cru exceptionnel**In original wooden case. Five very slightly damaged labels. Integrated US import labels. Levels into neck*6021 12 bottles *per lot* HK\$160,000-220,000**Petrus 1998***Pomerol, cru exceptionnel**In original wooden case. US import slip labels, one slightly damaged. Levels into neck*6022 6 bottles *per lot* HK\$100,000-160,000**Château Lafleur 1970***Pomerol**One very slightly depressed cork. One very slightly damaged capsule. Slightly stained and slightly damaged US import slip labels. Levels two base of neck and one top-shoulder*6023 3 bottles *per lot* HK\$14,000-20,000

Lot 6020



2000
Chateau Lafleur
MIS EN BOUTEILLES AU CHATEAU
Pomerol
M. Pomerol
PROPRIETAIRE
APPELLATION POMEROL CONTROLEE
1354
Cuvée de Réserve, Vignobles à Pomerol France
PRODUIT DE FRANCE

IMPORTED BY MARDELLI
PRODUCT OF FRANCE
ALC 14-16% BY VOL
GOVERNMENT WARNING

2000
Chateau Lafleur
MIS EN BOUTEILLES AU CHATEAU
Pomerol
M. Pomerol
APPELLATION POMEROL CONTROLEE

2000
Chateau Lafleur
MIS EN BOUTEILLES AU CHATEAU
Pomerol
M. Pomerol
APPELLATION POMEROL CONTROLEE

Lot 6024

Château Lafleur 2000

Pomerol
US import slip labels

6024 3 bottles per lot HK\$26,000-38,000

Château Lafleur 2001

Pomerol
In original wooden case

6025 3 magnums per lot HK\$15,000-20,000

Château Cheval-Blanc 1990

Saint-Émilion, 1er grand cru classé (A)
In original wooden case. Four very slightly stained labels. Levels into neck

6026 12 bottles per lot HK\$70,000-100,000

Château Canon 1961

Saint-Émilion, 1er grand cru classé
One corroded and slightly damaged capsule. Badly stained, two damaged and ten slightly damaged Nicolas stamped labels. Levels one base of neck, five top-shoulder, four upper-shoulder and two mid-upper shoulder

6027 12 bottles per lot HK\$20,000-30,000

Château Canon 1982

Saint-Émilion, 1er grand cru classé
Very slightly damaged capsules. Stained labels. US import slip labels. Levels into neck

6028 6 bottles per lot HK\$8,000-12,000

Château Haut-Brion Blanc 1989

Pessac (Graves), cru classé
One corroded capsule. Three very slightly damaged labels. Five slightly stained and slightly damaged US import slip labels. Levels four 1.5cms, one 2.5cms and one 3cms

6029 6 bottles per lot HK\$70,000-100,000

Château Haut-Brion Blanc 1993

Pessac (Graves), cru classé
In six-magnum original wooden case. Two very slightly damaged labels. Levels one 1.5cms and two 2cms

6030 3 magnums per lot HK\$20,000-30,000

Château de Rayne-Vigneau 1957

Bommes (Sauternes), 1er cru classé
In original wooden case. Recorked at the Château in 2010. Four stained, four very slightly damaged, one slightly damaged and three slightly wrinkled labels. Levels into neck

6031 12 bottles per lot HK\$16,000-24,000

Mixed Chambertin & Chambertin-Clos-de-Bèze 1969

1969 Armand Rousseau, Chambertin (1)
Corroded capsule. Stained and damaged label. US import slip label. Level 2cms

1969 Armand Rousseau, Chambertin-Clos-de-Bèze (1)
Stained vintage neck label. Stained and damaged label. US import slip label. Level 1.5cms

6032 Above 2 bottles per lot HK\$50,000-85,000



Lot 6030

Domaine Armand Rousseau, Chambertin 1996*Grand Cru, Côte de Nuits**Two US import slip labels. Levels two 1cm and one 1.5cms*6033 3 bottles *per lot* HK\$30,000-45,000**Domaine Armand Rousseau, Gevrey-Chambertin, Clos Saint-Jacques 2005***Côte de Nuits**In original carton*6034 12 bottles *per lot* HK\$60,000-80,000**Domaine Comte Georges de Vogüé, Bonnes-Mares 1959***Grand Cru, Côte de Nuits**Stained and one damaged labels. US import slip labels. Levels two 3.5cms and one 4cms*6035 3 bottles *per lot* HK\$40,000-60,000**Domaine Comte Georges de Vogüé, Musigny Vieilles Vignes 1999***Grand Cru, Côte de Nuits**One very slightly stained and one very slightly damaged label*6036 3 bottles *per lot* HK\$15,000-24,000**Domaine Comte Georges de Vogüé, Musigny Vieilles Vignes 2002***Grand Cru, Côte de Nuits**One very slightly stained label. US import slip labels*6037 6 bottles *per lot* HK\$30,000-45,000**Domaine de la Romanée-Conti, Romanée-Conti 1988***Grand Cru, Côte de Nuits**In original wooden case. Slightly corroded capsules, otherwise excellent appearance. Leroy slip labels.**Green roundels on labels. Levels one 1.5cms, two 2cms, five 2.5cms and four 3cms*6038 12 bottles *per lot* HK\$1,000,000-1,600,000**Domaine de la Romanée-Conti, Romanée-Conti 2001***Grand Cru, Côte de Nuits**Four Wilson Daniels import back labels, one German. Two US import slip labels*6039 6 bottles *per lot* HK\$450,000-650,000**Domaine de la Romanée-Conti, La Tâche 1982***Grand Cru, Côte de Nuits**Three slightly corroded capsules. Two very slightly damaged vintage neck labels. Five Leroy slip labels.**One Danish and one UK import slip labels. Levels two 2cms, one 2.5cms, two 4cms and one 4.5cms*6040 6 bottles *per lot* HK\$60,000-90,000**Domaine de la Romanée-Conti, La Tâche 1996***Grand Cru, Côte de Nuits**In banded original wooden case*6041 6 bottles *per lot* HK\$90,000-130,000**Domaine de la Romanée-Conti, La Tâche 1999***Grand Cru, Côte de Nuits**Wilson Daniels import back labels*6042 3 bottles *per lot* HK\$80,000-120,000**Domaine de la Romanée-Conti, La Tâche 2001***Grand Cru, Côte de Nuits**In original wooden case*6043 6 bottles *per lot* HK\$100,000-140,000**Domaine de la Romanée-Conti, La Tâche 2002***Grand Cru, Côte de Nuits**In original wooden case*6044 6 bottles *per lot* HK\$110,000-150,000**Domaine de la Romanée-Conti, La Tâche 2004***Grand Cru, Côte de Nuits**Wilson Daniels import back labels*6045 6 bottles *per lot* HK\$90,000-130,000



MONOPOLE
2002

SOCIÉTÉ CIVILE DU DOMAINE DE LA ROMANÉE-CÔTÉ
PROPRIÉTAIRE A VOSNE-ROMANÉE (COTE-D'OR) FRANCE

LA TÂCHE
APPELLATION LA TÂCHE CONTRÔLÉE

17.343 Bouteilles Récoltes
LES ASSOCIÉS-GÉRANTS

BOUTEILLE N° 00933
ANNÉE 2002

Henri Jubeau-Pohl
A. d. V. é. m.

Mise en bouteille au domaine

LA TÂCHE
APPELLATION LA TÂCHE CONTRÔLÉE

Domaine de la Romanée-Conti, Richebourg 2007
Grand Cru, Côte de Nuits
In banded original wooden case
6046 6 bottles per lot HK\$50,000-70,000

DRC Assortment 2000

2000 Domaine de la Romanée-Conti, Romanée-Conti (1)
2000 Domaine de la Romanée-Conti, La Tâche (3)
2000 Domaine de la Romanée-Conti, Richbourg (2)
2000 Domaine de la Romanée-Conti, Romanée-Saint-Vivant (2)
2000 Domaine de la Romanée-Conti, Grands-Echézeaux (2)
2000 Domaine de la Romanée-Conti, Echézeaux (2)
In banded original wooden case
6047 Above 12 bottles per lot HK\$200,000-300,000

DRC Superlot 2009

2009 Domaine de la Romanée-Conti, Romanée-Conti (3)
In banded original wooden case
2009 Domaine de la Romanée-Conti, La Tâche (6)
In banded original wooden case
2009 Domaine de la Romanée-Conti, Richbourg (6)
In banded original wooden case
2009 Domaine de la Romanée-Conti, Grands-Echézeaux (6)
In banded original wooden case
2009 Domaine de la Romanée-Conti, Echézeaux (6)
In banded original wooden case
2009 Domaine de la Romanée-Conti, Romanée-Saint-Vivant (6)
In banded original wooden case
2009 Domaine de la Romanée-Conti, Corton (6)
In banded original wooden case
2009 Domaine de la Romanée-Conti, Montrachet (3)
In banded original wooden case
6048 Above 42 bottles per lot HK\$700,000-1,000,000

Henri Mayer, Echézeaux 1978

Grand Cru, Côte de Nuits
No capsule. Level 5 cms
6049 1 magnum per lot HK\$90,000-120,000

Domaine Leroy, Latricières-Chambertin 1996

Grand Cru, Côte de Nuits
One very slightly protruding cork. One very slightly damaged label. UK import slip labels. Levels 1.5cms
6050 2 bottles per lot HK\$24,000-35,000

Domaine Leroy, Latricières-Chambertin 1999

Grand Cru, Côte de Nuits
In original wooden case. Signs of old seepage. One wrinkled and one slightly damaged labels. US import slip labels. Levels 1.5cms or better
6051 12 bottles per lot HK\$120,000-180,000

Domaine Leroy, Latricières-Chambertin 2001

Grand Cru, Côte de Nuits
One sign of old seepage. One damaged wax capsule. One slightly stained and one slightly damaged labels. UK import slip labels. Levels one 1.5cms and one 2cms
6052 2 bottles per lot HK\$18,000-26,000

Hubert Lignier, Clos de la Roche 2002

Grand Cru, Côte de Nuits
US import slip labels
6053 3 bottles per lot HK\$9,000-13,000

Domaine Méo-Camuzet, Clos de Vougeot 2002

Grand Cru, Côte de Nuits
US import slip labels
6054 6 bottles per lot HK\$12,000-18,000

Domaine Méo-Camuzet, Nuits-Saint-Georges Les Boudots 1993

1er Cru, Côte de Nuits
6055 6 bottles per lot HK\$12,000-18,000

Domaine Méo-Camuzet, Nuits-Saint-Georges Les Boudots 1996

1er Cru, Côte de Nuits
Four slightly damaged vintage neck labels. One very slightly stained label and one very slightly damaged label. US import slip labels
6056 6 bottles per lot HK\$12,000-18,000

Domaine Méo-Camuzet, Nuits-Saint-Georges Les Boudots 1999

1er Cru, Côte de Nuits
US import slip labels
6057 6 bottles per lot HK\$12,000-18,000

Mommessin, Clos de Tart 1995

Grand Cru, Côte de Nuits

In original wooden case

6058 3 magnums *per lot* HK\$9,000-14,000

Mommessin, Clos de Tart 2005

Grand Cru, Côte de Nuits

In original wooden case

6059 3 magnums *per lot* HK\$16,000-24,000

Domaine Jacques-Frédéric Mugnier, Musigny 1990

Grand Cru, Côte de Nuits

Two stained and one very slightly wrinkled labels. One

US import slip label. Levels one 1cm and two 1.5cms

6060 3 bottles *per lot* HK\$35,000-50,000

Domaine Jacques-Frédéric Mugnier, Musigny 1993

Grand Cru, Côte de Nuits

Two slightly stained and slightly damaged labels. US import slip labels. Levels two 1.5cms and one 2cms

6061 3 bottles *per lot* HK\$35,000-50,000

Domaine Jacques-Frédéric Mugnier, Musigny 2005

Grand Cru, Côte de Nuits

In original wooden case

6062 6 bottles *per lot* HK\$90,000-130,000

Domaine Ponsot, Clos de la Roche Vieilles Vignes 2009

Grand Cru, Côte de Nuits

In original wooden case

6063 3 magnums *per lot* HK\$18,000-26,000



Lot 6062



Lot 6073

Domaine Jean-Pierre Mathieu, Charmes-Chambertin Aux Mazoyères 2011

*Grand Cru, Côte de Nuits
In six-bottle original carton. Bottled by Christophe Roumier*

6064 12 bottles *per lot* HK\$30,000-45,000

Domaine Georges Roumier, Bonnes-Mares 2004

*Grand Cru, Côte de Nuits
In six-bottle original cartons. US import slip labels*

6065 12 bottles *per lot* HK\$35,000-50,000

Domaine Georges Roumier, Bonnes-Mares 2006

*Grand Cru, Côte de Nuits
In six-bottle original cartons*

6066 12 bottles *per lot* HK\$40,000-60,000

Jean-François Coche-Dury, Corton-Charlemagne 2004

*Grand Cru, Côte de Beaune
Congée capsules. Two very slightly damaged labels.
US import back labels. Excellent levels*

6067 3 bottles *per lot* HK\$50,000-75,000

6068 NO LOT

Domaine d'Auvenay, Chevalier-Montrachet 2000

Côte de Beaune

6069 3 bottles *per lot* HK\$70,000-100,000

Domaine d'Auvenay, Puligny-Montrachet Les Foliatières 2000

*1er Cru, Côte de Beaune
One very slightly damaged capsule*

6070 6 bottles *per lot* HK\$30,000-40,000

Domaine Leroy, Corton-Charlemagne 1990

*Grand Cru, Côte de Beaune
In original wooden case. Signs of old seepage. Slightly damaged wax capsules. One stained and two very slightly stained vintage neck labels. Four very slightly stained labels. Levels two 1.5cms, four 2cms, five 2.5cms and one 3cms*

6071 12 bottles *per lot* HK\$80,000-120,000

Domaine Leroy, Corton-Charlemagne 1991

*Grand Cru, Côte de Beaune
In original wooden case. Signs of old seepage. Five very slightly damaged capsules. Two slightly stained vintage neck labels. One very slightly damaged label. Levels four 2cms, five 2.5cms and three 3cms*

6072 12 bottles *per lot* HK\$60,000-90,000

Domaine Jean-Louis Chave, Ermitage Cuvée Cathelin 2003

*Rhône
One sign of old seepage. One slightly detached neck label. US import slip labels*

6073 3 bottles *per lot* HK\$80,000-120,000

Domaine Jean-Louis Chave, Hermitage 2003

*Rhône
One slightly stained neck label. One slightly damaged label. US import slip labels*

6074 6 bottles *per lot* HK\$18,000-28,000

FINEST & RAREST BORDEAUX & BURGUNDY FROM AN EXCEPTIONAL PRIVATE COLLECTION

We are privileged to be able to offer the following lots 6075 to 6113; part of a superb private collection of some of the finest wines from Bordeaux and Burgundy. The collection encompasses the finest wines from the most prestigious producers from the Right Bank of Bordeaux; Petrus, Le Pin & Lafleur and from Burgundy; fine vintages from Domaine de la Romanée-Conti, Dugat-Py, Domaine Leroy and Mommessin.

The wines were stored in impeccable temperature and humidity controlled professional storage prior to shipment specifically for the sale. The wines were inspected in situ and once again in Hong Kong by Christie's Specialists and the conditions are excellent with many offered in their original wooden cases. The wines were purchased from reputable sources and auction houses.

波爾多及勃艮第極品稀世佳釀私人珍藏

我們有幸呈獻來自波爾多和勃艮第的頂級美酒私人珍藏，拍品編號為 6075 至 6113。此系列匯聚波爾多右岸的名釀，以及勃艮第的柏翠、里鵬、花堡，還有羅曼尼康帝、杜卡皮、樂樺和摩曼森的年代珍藏。

在拍品付運前，此組珍藏皆儲藏於有嚴格溫度和濕度控制的酒窖內。藏品先後由佳士得專家在酒窖現場和香港進行檢查，確保狀態完好，大部分更放置於原裝木箱中。所有葡萄酒均來源顯赫或購自著名拍賣行。

Petrus 1995

Pomerol, cru exceptionnel

Excellent appearance. Levels into neck

6075 3 bottles *per lot* HK\$32,000-48,000



Lot 6076

Petrus 1998

Pomerol, cru exceptionnel

In six bottle original wooden cases. One very slightly damaged label otherwise excellent appearance. Levels into neck

6076 12 bottles *per lot* HK\$180,000-260,000

Mixed 2001 & 2006 Petrus

2001 Petrus

(3)

2006 Petrus

(3)

Excellent appearance. Levels into neck

6077 Above 6 bottles *per lot* HK\$65,000-100,000

Le Pin 1995

Pomerol

In original wooden case. Excellent appearance. Levels into neck

6078 10 bottles *per lot* HK\$100,000-150,000

Le Pin 2001

Pomerol

In six bottle original wooden cases. Excellent appearance. Levels into neck

6079 12 bottles *per lot* HK\$160,000-240,000

Lots 6078-6079

Luohan Vegetables Deluxe and Le Pin

The dish "Luohan Vegetables Deluxe" takes its roots from Jiangsu, Zhejiang cuisine. Despite the Buddhist reference, 'luohan' meaning arhat, in its name, the dish is not originated from Buddhism. It is commonly seen in Han family meals in the Jiangsu, Zhejiang regions and widely featured in birthday banquets in Southern China.

A traditional Luohan Vegetables Deluxe is based on shiitake mushrooms, accompanied by other vegetarian ingredients like dried tofu sheets, black fungi, bamboo shoots, carrots and St. George's mushrooms, etc. After being sliced, julienned or treated with decorative cuts, the vegetables are sautéed, drizzled with rice wine and seasoning before sesame oil and a light glazing sauce is poured on the delicacy at the moment of serving.

Led by mushrooms and complemented with assorted vegetables, Luohan Vegetables Deluxe is refreshing and light on the palate. A great wine to drink with the dish is Le Pin of Pomerol. Predominately Merlot, Le Pin possesses rich, round fruit scents with silky tannins, and will strike an interesting harmony with the particular fragrance and unctuous texture of mushrooms.

Early 2016. Austin Zhang.

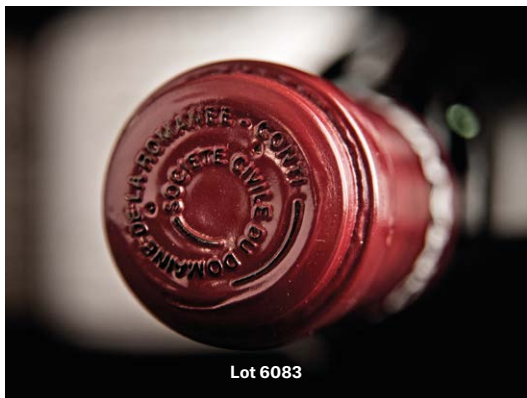

Lot 6083

Château Lafleur 1990

Pomerol

Berry Bros & Rudd Japanese import back labels. Glue-stripped labels, one slightly damaged. Levels base of neck or better

6080 6 bottles *per lot* HK\$45,000-70,000

Mixed Château Lafleur 1996 & 1998

Château Lafleur 1996

In six bottle original wooden case. Excellent appearance. Levels base of neck or better

(6)

Château Lafleur 1998

In six bottle original wooden case. Excellent appearance. Levels base of neck or better

(6)

6081 Above 12 bottles *per lot* HK\$26,000-35,000

Mixed Château Lafleur 1999 & 2004

Château Lafleur 1999

In six bottle original wooden case. Excellent appearance. Levels into neck

(6)

Château Lafleur 2004

In six bottle original wooden case. Excellent appearance. Levels into neck

(6)

6082 Above 12 bottles *per lot* HK\$26,000-35,000

Domaine de la Romanée-Conti, Richebourg 2003

Grand Cru, Côte de Nuits

Berry Bros & Rudd Japanese import back labels. One slightly stained label

6083 3 bottles *per lot* HK\$28,000-38,000

Lot 6083

炒雞腿蘑菇配 DRC Richebourg

蕪湖大庵和尚，洗淨雞腿，蘑菇去沙，加秋油、酒炒熟，盛盤宴客，甚佳。李察堡是勃艮第最優質的特級田之一，不但具有典型的沃內-羅曼尼村葡萄酒的優雅，而且從結構和深度上都相當的精良。羅曼尼康帝酒園出產的李察堡花香濃郁，充滿活力，給人一種奢華的感覺。這道簡單但卻不簡約的炒雞腿蘑菇，菌菇和雞肉的香氣柔弱但卻有力道，映襯李察堡強大的香氣而不失本味。

張脩翰，2013年8月

Fried Mushroom and Chicken with DRC Richebourg

Richebourg is one of the finest Grand Cru in the Côte de Nuits. It has the typical elegance of Vosne Romanée along with structure and depth. DRC Richebourg displays rich floral aromas and vibrant acidity. Sumptuous is the exact word to describe it. This fried mushroom and chicken is delicate, but never simple, because the flavors of the ingredients are long-lasting and powerful. It would be a perfect match for the great Richebourg; neither the food nor wine will overpower each other.

Austin Zhang, August 2013

Domaine de la Romanée-Conti, Romanée-Saint-Vivant 1978

Grand Cru, Côte de Nuits

Berry Bros & Rudd Japanese Import back labels. Good colour. Leroy slip labels. Four very slightly damaged capsules. Three slightly stained, two stained and one badly stained label. Levels one 2cms, three 2.5cms, two 3cms, two 3.5cms and two 4cms

6084 10 bottles *per lot* HK\$85,000-130,000

Domaine de la Romanée-Conti, Romanée-Saint-Vivant 2003

Grand Cru, Côte de Nuits

Berry Bros & Rudd Japanese import back labels. Four very slightly stained labels otherwise excellent appearance. Levels high fill

6085 12 bottles *per lot* HK\$85,000-120,000

DRC Assortment 1988**1988 Domaine de la Romanée-Conti, Romanée-Conti** (1)

Very slightly damaged capsule. Very slightly stained label. Green roundel on label. Level 2.5cms

1988 Domaine de la Romanée-Conti, La Tâche (3)

One stained, one stained and slightly damaged and one badly stained and damaged label and vintage neck label. Levels one 2cms, one 2.5cms & one 3cms

1988 Domaine de la Romanée-Conti, Richebourg (2)

Badly stained labels, one slightly damaged. Levels one 3cms and one 3.5cms

1988 Domaine de la Romanée-Conti, Romanée-Saint-Vivant (3)

Stained labels, one slightly damaged. Levels two 1cm and one 1.5cms

1988 Domaine de la Romanée-Conti, Grands-Echézeaux (1)

Very slightly stained label. Level 1.5cms

1988 Domaine de la Romanée-Conti, Echézeaux (2)

Stained and damaged labels. Levels 1cm or better

6086 Above 12 bottles per lot HK\$140,000-220,000

DRC Assortment 1988**1988 Domaine de la Romanée-Conti, Romanée-Conti** (1)

Slightly damaged and corroded capsule. Very slightly damaged label. Level 3cms

1988 Domaine de la Romanée-Conti, La Tâche (3)

Two slightly damaged and corroded capsules.

Two very slightly damaged labels. Levels one 2.5cms, one 3cms and 3.5cms

1988 Domaine de la Romanée-Conti, Richebourg (2)

One slightly damaged and corroded capsule. One very slightly stained label. Levels 2cms and 2.5cms

1988 Domaine de la Romanée-Conti, Romanée-Saint-Vivant (3)

One slightly damaged capsule. Levels 2cms

1988 Domaine de la Romanée-Conti, Grands-Echézeaux (1)

Level 2cms

1988 Domaine de la Romanée-Conti, Echézeaux (2)

All with Wilson Daniels US import slip labels

6087 Above 12 bottles per lot HK\$140,000-200,000

DRC Assortment 1989**1989 Domaine de la Romanée-Conti, Romanée-Conti** (1)

Stained label. Level 1.5cms

1989 Domaine de la Romanée-Conti, La Tâche (1)

Very slightly stained label. Level 1cm

1989 Domaine de la Romanée-Conti, Richebourg (2)

Levels 1cm and 2cms

1989 Domaine de la Romanée-Conti, Romanée-Saint-Vivant (1)

Very slightly damaged capsule. Level 2cms

1989 Domaine de la Romanée-Conti, Grands-Echézeaux (1)

Very slightly stained label. Level 1.5cms

1989 Domaine de la Romanée-Conti, Echézeaux (1)

Very slightly stained label. Level 1.5cms

6088 Above 7 bottles per lot HK\$100,000-150,000

DRC Assortment 1989**1989 Domaine de la Romanée-Conti, Romanée-Conti** (1)

Level 1.5cms

1989 Domaine de la Romanée-Conti, La Tâche (3)

One slightly stained label. Two very slightly depressed corks. Levels 2cms or better

1989 Domaine de la Romanée-Conti, Richebourg (2)

Levels 1.5cms

1989 Domaine de la Romanée-Conti, Romanée-Saint-Vivant (3)

Levels 1.5cms or better

1989 Domaine de la Romanée-Conti, Grands-Echézeaux (1)

Level 2cms

1989 Domaine de la Romanée-Conti, Echézeaux (2)

Levels 1cm

6089 Above 12 bottles per lot HK\$130,000-200,000

DRC Assortment 1995**1995 Domaine de la Romanée-Conti, Romanée-Conti** (1)

Very slightly stained and very slightly damaged label. Level 1cm

1995 Domaine de la Romanée-Conti, La Tâche (3)

Levels 2cms

1995 Domaine de la Romanée-Conti, Richebourg (2)

Levels one 1cm and one 2cms

1995 Domaine de la Romanée-Conti, Romanée-Saint-Vivant (2)

Levels one 1.5cms and one 2.5cms

1995 Domaine de la Romanée-Conti, Grands-Echézeaux (2)

Levels 1.5cms

1995 Domaine de la Romanée-Conti, Echézeaux (2)

Levels 1.5cms

6090 Above 12 bottles per lot HK\$150,000-220,000

2000 BURGUNDY VINTAGE REPORT

Flowering took place in excellent conditions throughout the region, to be followed by a dreadful month of July, with low temperatures, rain and little sun. August turned hot, and the vines made up lost ground. Rain returned in early September, and a heavy thunderstorm on 12th September caused flooding, particularly on the Côte de Beaune, forcing some growers to start picking immediately. White wines are generally excellent, and broadly, Côte de Nuits reds out-performed those from its rival Côte. Many village level and 1st Growth reds matured rapidly, showing attractive, soft fruitiness, and were consumed while youthful. The best Grands Crus from Côte de Nuits matured at a steady pace, developing fine aromas, and gaining complexity. This is an elegant, light-bodied vintage, with well-softened tannins which may be enjoyed today, and over the coming 2-5+ years. Anthony Hanson MW

2000年勃艮第年份報告

全區的開花期天氣非常理想，但七月寒冷、降雨、日照較少。八月炎熱，不利於葡萄樹生長。九月初再度降雨，9月12日的大暴雨更造成洪水氾濫，伯恩丘產區尤其嚴重，部分莊園被逼提早採摘。大部分白酒品質優良，而夜丘出品的紅酒則普遍更勝其他產區。很多村莊級和一級葡萄園紅酒迅速成熟，散發出迷人的，柔和的水果風味，適合趁年輕飲用。夜丘地區的特級葡萄園以穩定的速度成熟，發展出優雅的香味，變得複雜。這是一個優雅的，輕酒體年份，柔和的單寧適合現在飲用，以及未來的2-5年。

DRC Assortment 2000

2000 Domaine de la Romanée-Conti, Romanée-Conti (1)

2000 Domaine de la Romanée-Conti, La Tâche (3)

2000 Domaine de la Romanée-Conti, Richebourg (2)

2000 Domaine de la Romanée-Conti, Romanée-Saint-Vivant (2)

2000 Domaine de la Romanée-Conti, Grands-Echézeaux (2)

2000 Domaine de la Romanée-Conti, Echézeaux (2)

In original wooden case. Wilson Daniels US import back labels. Excellent appearance and levels

6091 Above 12 bottles per lot HK\$150,000-220,000

2001 BURGUNDY VINTAGE REPORT

Flowering was spread out, resulting in uneven ripening, then summer weather was fitful, sometimes scorching, sometimes overcast. Hail on 2nd August damaged vineyards in the central Côte de Beaune, but, happily, high temperatures and dry weather mitigated its effects. Good weather, before and during the harvest allowed natural sugars to build up well, for bunches to ripen, and acidities be retained. Generally, the whites do not have the ripeness of 2000, but show crisp, citrus aromas with good, freshness. The reds have good aging potential with fine flavour concentration. Côte de Nuits Grand Crus reds excelled, and are now reaching their peaks. Anthony Hanson MW

2001年勃艮第年份報告

由於開花期不統一，果實成熟不均。夏季天氣陰晴不定，時而酷熱，時而陰天。8月2日的冰雹破壞伯恩丘中部的葡萄園，幸好高溫乾燥的天氣紓緩部分影響。採摘前和採摘期間天氣宜人，讓果實有時間積聚糖份及成熟，同時保留酸度。整體而言，白酒的成熟度不及2000年，但帶有清新酸爽的柑橘香氣。紅酒果味濃醇，具陳年潛力。夜丘特級葡萄園的出品出類拔萃，現在已達到巔峰期。

DRC Assortment 2001

2001 Domaine de la Romanée-Conti, Romanée-Conti (1)

2001 Domaine de la Romanée-Conti, La Tâche (3)

2001 Domaine de la Romanée-Conti, Richebourg (2)

2001 Domaine de la Romanée-Conti, Romanée-Saint-Vivant (2)

2001 Domaine de la Romanée-Conti, Grands-Echézeaux (2)

2001 Domaine de la Romanée-Conti, Echézeaux (2)

In original wooden case. Wilson Daniels US import back labels. Excellent appearance and levels

6092 Above 12 bottles per lot HK\$140,000-220,000



2002 BURGUNDY VINTAGE REPORT

The flowering went well, then it was followed by a lack of sun during July and August, with below-average temperatures, and, mercifully, below average rainfall in the Côte d'Or. At the end of August there were strong rains and low temperatures, but fine weather returned, bringing about ample natural sugar levels. Acidity was retained, thanks to clear skies and drying winds. It has proved to be a superb white Burgundy vintage, and the best reds – although lightly structured and somewhat discreet while youthful – are now filling out, developing spicy aromas, and seeing their tannins soften, as they come into balance. Anthony Hanson MW

2002年勃艮第年份報告

開花過程順利，七月及八月日照較少，溫度偏低，幸好金丘地區的降雨量低於平均水平。八月底降雨多和溫度低，但是好天氣回來了，帶來了充足的天然糖分。多虧晴朗的天空以及乾燥的風，葡萄保持了酸度。事實證明，這是一流的勃艮第白酒好年份，最好的紅酒雖然結構比較輕，年輕的酒比較內斂，但是現在變得圓潤，發展出辛香味，單寧變得柔和，整體變得優雅平衡。

DRC Assortment 2002

2002 Domaine de la Romanée-Conti, Romanée-Conti (1)

Very slightly stained label. Level high fill

2002 Domaine de la Romanée-Conti, La Tâche (3)

2002 Domaine de la Romanée-Conti, Richebourg (1)

2002 Domaine de la Romanée-Conti, Romanée-Saint-Vivant (3)

2002 Domaine de la Romanée-Conti, Grands-Echézeaux (2)

2002 Domaine de la Romanée-Conti, Echézeaux (3)

Excellent appearance and levels

6093 Above 13 bottles per lot HK\$150,000-240,000

DRC Grands-Echézeaux Vertical

1988 Domaine de la Romanée-Conti, Grands-Echézeaux (4)

Wilson Daniels US import slip labels. Two badly corroded capsules. One damaged label. Levels 2cms or better

1989 Domaine de la Romanée-Conti, Grands-Echézeaux (1)

Wilson Daniels US import back label. Slightly stained label. Level 1cm

1996 Domaine de la Romanée-Conti, Grands-Echézeaux (1)

Wilson Daniels US import back label. Slightly stained label. Level 1cm

6094 Above 6 bottles per lot HK\$38,000-55,000

DUGAT-PY

The Dugat family have been winegrowers in the Gevrey-Chambertin appellation since the beginning of the 17th century. Bernard Dugat and his son, Loïc are the 12th and 13th generation to continue the tradition. 1975 was Bernard's first vintage. Domaine Dugat-Py was started in 1994 with the addition of Bernard's wife, Jocelyn's maiden name.

Since 2003 the vineyards have been run along organic and biodynamic principles. The Domaine owns 9.81 hectares and includes four Grand Crus; Grand Cru; Chambertin (0.05 hectares), Mazis-Chambertin (0.22 hectares), Charmes-Chambertin(0.69 hectares), and Mazoyères-Chambertin and also the famed Premier Cru Gevrey-Chambertin Lavaux-Saint-Jacques.

The grapes are partially de-stemmed and fermented at up to 30 degrees. The Grand Crus are generally aged in 100% new oak for between 18 to 26 months and are not filtered prior to bottling.

The Domaine is famous for their four Grand Cru wines and quality has improved significantly over the last decade or so. These wines are concentrated and rich, and perfectly balanced. The wines generally need time to evolve and show at their best with 5-8 years of bottle ageing.

Domaine Dugat-Py, Charmes-Chambertin 1999

Grand Cru, Côte de Nuits

One original six-bottle carton. Excellent appearance and levels

6095 18 bottles per lot HK\$40,000-60,000

Domaine Dugat-Py, Charmes-Chambertin 2001

Grand Cru, Côte de Nuits

Excellent appearance and levels

6096 12 bottles per lot HK\$19,000-28,000

Domaine Dugat-Py, Charmes-Chambertin 2003

Grand Cru, Côte de Nuits

In original six-bottle cartons. Excellent appearance and levels

6097 11 bottles per lot HK\$20,000-32,000

Mixed Charmes-Chambertin 2002 & Mazis-Chambertin 2003 from Dugat-Py

2002 Dugat-Py, Charmes-Chambertin (6)

In original six-bottle carton. Excellent appearance and levels

2003 Dugat-Py, Mazis-Chambertin (6)

In original six-bottle carton. Excellent appearance and levels

6098 Above 12 bottles per lot HK\$26,000-40,000

Mixed 1999 & 2001 Mazis-Chambertin from Dugat-Py

1999 Dugat-Py, Mazis-Chambertin (5)
2001 Dugat-Py, Mazis-Chambertin (4)

Excellent appearance and levels

6099 Above 9 bottles per lot HK\$24,000-32,000

Mixed 2002 Mazis-Chambertin & Charmes-Chambertin from Dugat-Py

2002 Dugat-Py, Mazis-Chambertin (8)

Six in original carton. Two slightly damaged and two damaged labels. Excellent levels

2002 Dugat-Py, Charmes-Chambertin (10)

Six in original carton. One very slightly damaged label, otherwise excellent appearance and levels

6100 Above 18 bottles per lot HK\$48,000-70,000

Maison Leroy, Mazis-Chambertin 1978

Grand Cru, Côte de Nuits

Two very slightly damaged capsules. Berry Bros & Rudd Japanese import back labels. Three slightly stained labels. Levels three 1.5cms, two 2cms and three 2.5cms

6101 8 bottles per lot HK\$100,000-150,000

DOMAINE LEROY

The family can trace its history back to 1868 when François Leroy started the family wine business, Maison Leroy, which was the start of the négociant arm of the business (Maison Leroy wines are bought and therefore not vinified by Leroy). François Leroy's son, Henri acquired half of Domaine de la Romanée-Conti in the early 20th century. Henri's daughter Lalou Bize-Leroy established Domaine Leroy following the purchase of the 12 hectares of Domaine Noëllat in 1988 and Domaine Louis Remy in 1989 and she remains in charge to this day.

Domaine Leroy has adhered to the principles of biodynamic viticulture since 1989. They do not use any weed killers, pesticides, fungicides, insecticides or artificial fertilizers in their 23 hectares of vineyards. Incredibly low yields produce wines that are superbly concentrated and highly sought after.

There is a strict selection of only the finest grapes and resulting very low yields. For example in the challenging vintage of 2008 the yield was only 13 hectolitres per hectare. Grapes are not de-stemmed and whole clusters are fermented in old oak vats with temperature-control. The proportion of new oak varies depending on the wine and vintage.

Domaine Leroy produce nine Grand Cru wines; Corton-Renardes, Richebourg, Romanée-Saint-Vivant, Clos de Vougeot, Musigny, Clos de la Roche, Latricières-Chambertin, Chambertin and Corton-Charlemagne; as well as eight Premier Cru wines such as Vosne-Romanée Les Beaux-Monts and Gevrey-Chambertin Les Combottes, and a further selection of fine red wines such as Pommard and Nuits-Saint-Georges from other Burgundy terroirs. Domaine Leroy is regarded by many as one of the finest producers in Burgundy. Michel Bettane wrote in Vins de France that "Domaine Leroy is a welcome reminder of the difference between the very good and the great". And Robert Parker stated that "Lalou Bize-Leroy stands alone at the top of Burgundy's quality hierarchy. Because she is a perfectionist, and because she has had the courage to produce wines from low yields and bottle them naturally, without fining or filtration". Many would agree with Clive Coates when he says "This is the greatest estate in Burgundy..."

Domaine Leroy, Clos de Vougeot 1996

Grand Cru, Côte de Nuits

US import slip labels. Excellent appearance. Levels 1.5cms or better

6102 6 bottles per lot HK\$30,000-45,000

Domaine Leroy, Clos de Vougeot 2002

Grand Cru, Côte de Nuits

In original wooden case. US import back labels.

Three very slightly damaged wax capsules otherwise excellent appearance. Levels 2.5cms or better

6103 12 bottles per lot HK\$70,000-100,000

Lots 6102-6105

海南雞飯配 Leroy Clos de Vougeot

海南雞飯當然起源於海南，但揚名卻是在新馬泰，而海南本地人則以其起源地稱為文昌雞。雞肉用的是粵菜白斬雞的做法，沸水煮熟而成。海南雞飯的味道在於搭配雞肉的佐料和米飯。米飯要特別使用雞油和浸雞水煮，才能入味，有時還會加入姜片和蔥花調味。搭配雞肉的調料更為講究，各家做法也不同。最好的姜蒜調料多是在混合的姜和蒜末上，淋以熱油以充分萃取其香氣。辣椒醬則要選取上好的朝天椒，配上酸橙汁和鳳梨調味。而甜醬油則是與冰糖水同煮熬制而成，口感粘稠，香氣濃郁。搭配百變而充滿層次感的 Leroy 特級田 Clos de Vougeot 最好不過。Leroy 釀造的 Clos de Vougeot 可以算是這片勃艮第最大的特級田中的佼佼者，開瓶後如同進入百花園，果香豐富，單寧柔順，令人難以忘懷。

乙未秋日，張翕翰。

Domaine Leroy, Clos de Vougeot 2002*Grand Cru, Côte de Nuits**US import back labels. Four very slightly damaged wax capsules. One slightly stained label. Levels 2cms or better*

6104 12 bottles per lot HK\$70,000-100,000

Domaine Leroy, Clos de Vougeot 2005*Grand Cru, Côte de Nuits**In original wooden case. Japanese import back labels. Excellent appearance. Levels 1.5cms or better*

6105 12 bottles per lot HK\$60,000-90,000

Domaine Leroy, Nuits-Saint-Georges, Les Boudots 2005*1er Cru, Côte de Nuits**In original wooden case. Japanese import back labels. One with old signs of seepage and one very slightly damaged wax capsule, otherwise excellent appearance. Levels 1.5cms or better*

6106 12 bottles per lot HK\$45,000-70,000

Domaine Leroy, Vosne-Romanée, Les Beaux Monts 2005*In original wooden case. Japanese import back labels. Excellent appearance. Levels 1.5cms or better*

6107 12 bottles per lot HK\$40,000-60,000

Lot 6107

大盆雞配 Leroy Vosne Romanée Beaux Monts

大盆雞是一道紅遍中國的新疆美食，用料常見易得，不過是雞塊、土豆和皮帶面（也稱褲帶面，手擀的寬麵條）。做好的大盆雞香味誘人，麻辣鮮香，而且賣相極佳，從街頭的小吃店到正宗的新疆館子都是必點佳餚。這道菜的來源已經不可考證，而且也有不同的製作版本，但各種烹飪方法都反映著西北地方各種民族文化的大融合。雞肉、土豆和洋蔥是新疆地區少數民族菜肴的必備原料，而麵食則是西北地方漢族的傳統主食，帶來辣味的朝天椒則很明顯是受巴蜀地區川菜烹飪方法的影響。可以嘗試搭配勃艮第傳奇酒莊 Leroy 出產的 Vosne Romanee 村的一級田 Beaux Monts。Beaux Monts 釀造果香豐富，酸度怡人的黑比諾紅葡萄酒，品質堪比肩勃艮第的眾多特級田，搭配口感豐富、鮮嫩可口的雞肉是非常好的選擇。

乙未秋日，張儵翰。

Domaine Leroy, Pommard Les Vignots 2006*In original wooden case. Japanese import back labels. Excellent appearance. Levels 1.5cms or better*6108 12 bottles per lot HK\$16,000-26,000
6109 12 "**Domaine Leroy, Vosne-Romanée 2004***Côte de Nuits**In original wooden case. Japanese import back labels. Three with old signs of seepage, otherwise excellent appearance and levels*

6110 12 bottles per lot HK\$20,000-40,000

Domaine Leroy, Vosne-Romanée 2004*Côte de Nuits**In original wooden case. Japanese import back labels. Excellent appearance. Levels 1.5cms or better*

6111 12 bottles per lot HK\$20,000-40,000

CLOS DE TART

Clos de Tart is one of the Monopole Grand Crus. The ownership changed hands several times but Mommessin has owned it since 1932. And they have been a genuine star of burgundy since the end of the last century. Today the estate is run by Sylvain Pitot.

Clos de Tart is 7.53 hectares. To protect the vines against erosion, this monopole is planted in a unique north-south direction. From top to the bottom of this stony slope, the deep soils are made up from Bathonian calcareous and Bajocian soil, and the surface soil gets richer at the bottom of the slope. The average age of vines is around 55 years.

About 20% of the stems are kept during the cold soaking and fermentation. And after 16-24 months aging in 100 percent new oak, the wines are bottled without fining nor filtration.

The wine is often described as "feminine" with full body but Clive Coates MW disagrees and states that "the wine is robust and tannic with rich cherry fruit and a certain spice".

Mommessin, Clos de Tart 2003*Grand Cru, Côte de Nuits**In original wooden case. Japanese import back labels*

6112 12 bottles per lot HK\$14,000-24,000

Mommessin, Clos de Tart 2005*Grand Cru, Côte de Nuits**In original wooden case. Japanese import back labels*

6113 12 bottles per lot HK\$20,000-30,000

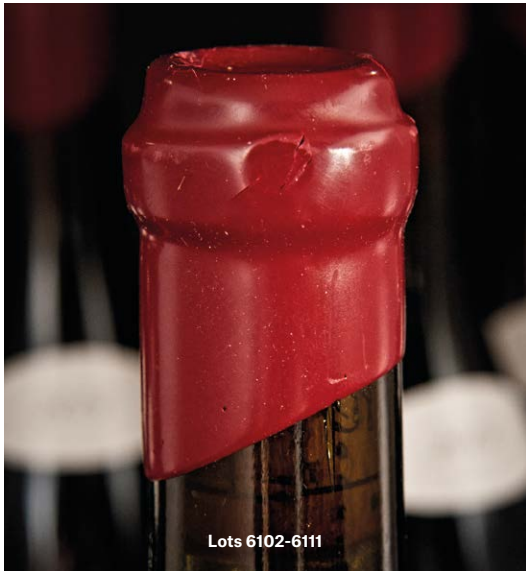

OUTSTANDING VINTAGES OF RED AND WHITE BORDEAUX FROM A PRIVATE COLLECTOR

The following lots 6114 to 6148 belong to a private collector. The wines were shipped from Octavian to Hong Kong specifically for this sale. The collection includes outstanding vintages of Lafite Rothschild and Carruades de Lafite from 1994 through to 2010 and exceptional vintages of Château Margaux, Haut Brion, Cos d'Estournel, Lynch-Bages and d'Yquem. The wines were purchased on release from respected merchants in the UK.

Château Cos d'Estournel 1982

*Saint-Estéphe, 2ème cru classé
Corroded and slightly damaged capsules. One slightly damaged label. Levels into neck*

6114 12 bottles per lot HK\$24,000-35,000

Château Lafite-Rothschild 1994

*Pauillac, 1er cru classé
In original wooden case. Excellent appearance. Levels into neck*

6115 12 bottles per lot HK\$38,000-55,000

Château Lafite-Rothschild 1998

*Pauillac, 1er cru classé
In original wooden case*

6116 12 bottles per lot HK\$45,000-70,000

Château Lafite-Rothschild 1999

*Pauillac, 1er cru classé
In original wooden case*

6117 12 bottles per lot HK\$40,000-60,000

Château Lafite-Rothschild 2001

*Pauillac, 1er cru classé
In original wooden case*

6118 12 bottles per lot HK\$40,000-60,000

Château Lafite-Rothschild 2004

*Pauillac, 1er cru classé
In original wooden cases*

6119 6 magnums per lot HK\$40,000-60,000
6120 6 "
6121 6 "

Château Lafite-Rothschild 2005

*Pauillac, 1er cru classé
In original wooden case*

6122 12 bottles per lot HK\$50,000-80,000



Château Lafite-Rothschild 2006*Pauillac, 1er cru classé
In original wooden case*6123 12 bottles *per lot* HK\$42,000-65,000**Château Lafite-Rothschild 2007***Pauillac, 1er cru classé
In original wooden cases*6124 12 bottles *per lot* HK\$40,000-60,000

6125 12 "

6126 12 "

Château Lafite-Rothschild 2009*Pauillac, 1er cru classé
In original wooden case*6127 6 magnums *per lot* HK\$55,000-80,000**Château Lafite-Rothschild 2009***Pauillac, 1er cru classé
In original wooden cases*6128 12 bottles *per lot* HK\$55,000-80,000

6129 12 "

Château Lafite-Rothschild 2010*Pauillac, 1er cru classé
In original wooden cases*6130 12 bottles *per lot* HK\$50,000-70,000

6131 12 "

Carruades de Lafite-Rothschild 2001*Pauillac
In original wooden case*6132 6 magnums *per lot* HK\$15,000-22,000**Carruades de Lafite-Rothschild 2004***Pauillac
In original wooden cases*6133 6 magnums *per lot* HK\$15,000-22,000

6134 6 "

6135 6 "

Carruades de Lafite-Rothschild 2005*Pauillac
In original wooden cases*6136 6 magnums *per lot* HK\$16,000-24,000

6137 6 "

Carruades de Lafite-Rothschild 2006*Pauillac
In original wooden case*6138 12 magnums *per lot* HK\$24,000-36,000**Carruades de Lafite-Rothschild 2007***Pauillac
In original wooden case*6139 12 magnums *per lot* HK\$30,000-44,000**Château Mouton Rothschild 2006***Pauillac, 1er cru classé
In original wooden case*6140 6 bottles *per lot* HK\$15,000-22,000**Château Lynch-Bages 1982***Pauillac, 5ème cru classé
Two damaged and corroded capsules. Eight base of
neck or better, two top and two upper-shoulder*6141 12 bottles *per lot* HK\$18,000-28,000

BAN

MIS EN BOUTEILLE AU CHÂTEAU

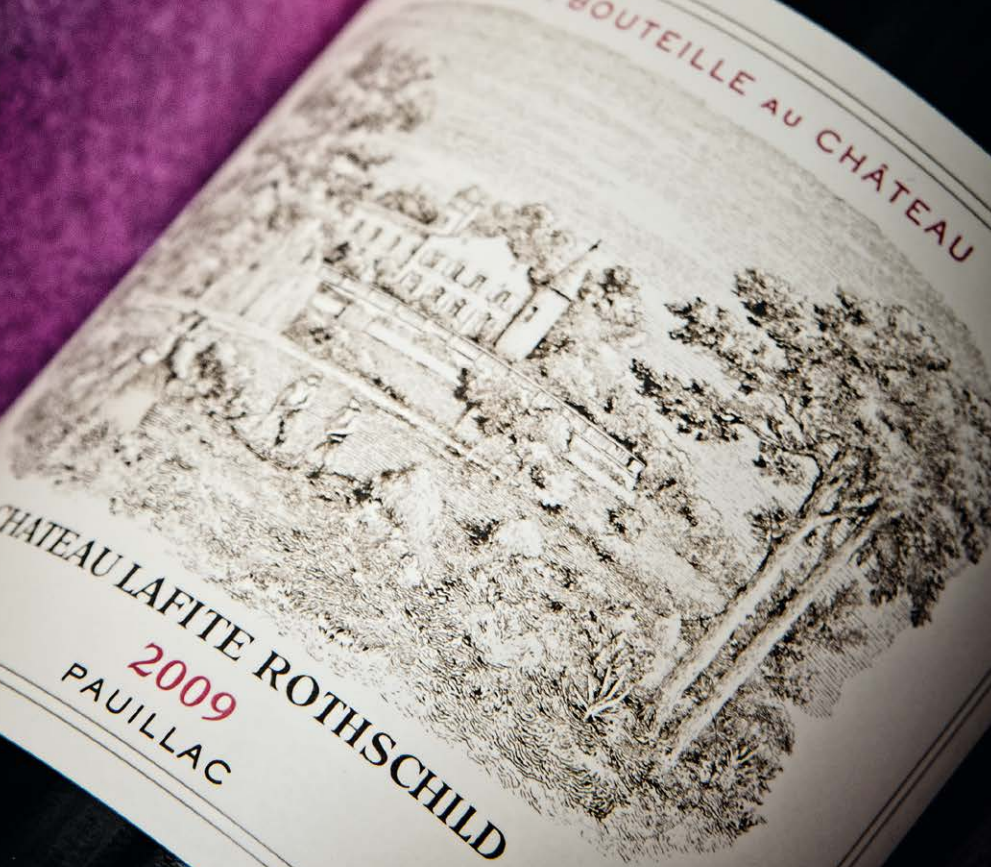

CHATEAU LAFITE ROTHSCHILD
2009
PAUILLAC

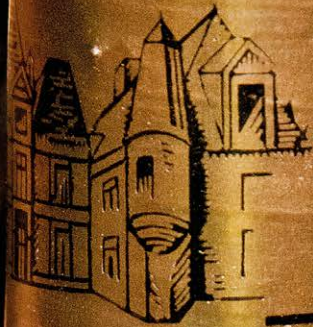

...BOUTEILLES AU CHATEAU ...

Château Margaux 1982*Margaux, 1er cru classé**In original wooden case. Levels base of neck or better*

6142 12 bottles per lot HK\$60,000-80,000

Château Margaux 1990*Margaux, 1er cru classé*

6143 12 bottles per lot HK\$65,000-90,000

Château Haut-Brion 1990*Pessac (Graves), 1er cru classé**In original wooden cases*

6144 12 bottles per lot HK\$45,000-70,000

6145 12 "

6146 12 "

Château d'Yquem 1989*Sauternes, 1er grand cru classé**In original wooden cases. Excellent appearance. Levels into neck*

6147 12 bottles per lot HK\$20,000-30,000

6148 12 "

BORDEAUX & CHAMPAGNE FROM THE OUTSTANDING 1995 VINTAGE**Château Latour 1995***Pauillac, 1er cru classé**Lots 6149-6154: In original wooden cases. Japanese import back labels. Levels into neck**Lot 6155: In original wooden case with damaged lid.**Japanese import neck labels. Levels into neck*

6149 12 bottles per lot HK\$38,000-60,000

6150 12 "

6151 12 "

6152 12 "

6153 12 "

6154 12 "

6155 12 "



Lots 6149-6155

Château Ducru-Beaucaillou 1995*Saint-Julien, 2ème cru classé**In original wooden case with slightly damaged lid. Japanese import back labels. Levels into neck*

6156 12 bottles per lot HK\$10,000-15,000

Château Ducru-Beaucaillou 1995*Saint-Julien, 2ème cru classé**In original wooden cases with slightly damaged lids. Japanese import back labels. Levels into neck*

6157 24 bottles per lot HK\$20,000-30,000

Château du Tertre 1995*Margaux, 5ème cru classé**In original wooden cases. Japanese import neck labels. Slightly stained labels. Levels into neck*

6158 24 bottles per lot HK\$7,500-11,000

Château Haut-Brion 1995*Pessac (Graves), 1er cru classé**Japanese import neck labels. One very slightly stained label. Levels 0.5cm*

6159 3 bottles per lot HK\$6,500-10,000

Château La Mission-Haut-Brion 1995

Pessac (Graves), cru classé

In original wooden cases. Japanese import neck labels. Two very slightly stained and three very slightly damaged labels. Levels into neck

6160 12 bottles per lot HK\$15,000-24,000
6161 12 ..

Mixed 1952 Latour & La Tâche

1952 Château Latour (1)

Damaged and cut capsule to reveal vintage and Latour branded cork. Damaged and stained label. Level into neck

1952 Domaine de la Romanée-Conti, La Tâche (1)

Slightly corroded capsule. Damaged and badly stained label. Level 1.5cms

6162 Above 2 bottles per lot HK\$14,000-22,000

Louis Roederer, Brut 1995

Japanese import back label

6163 1 magnum per lot HK\$3,200-4,800

2003 BORDEAUX VINTAGE REPORT

The year of the heatwave. Untypical reds entirely due to the exceptionally hot summer and early harvest. The early part of the growing season was unexceptional, satisfactory flowering predicting an appropriately early harvest. However temperatures in August were up to 40°C compared to "normal" Bordeaux heatwaves of around 34-35°C. This resulted in an unusually precocious harvest, producing a low volume of small, concentrated, very ripe grapes with thick skins.

Some great wines were made but several were disappointing. On the whole these are attractive wines. I tasted a very extensive range, mainly noted as en primeur wines in the spring of 2004. Michael Broadbent MW

2003年波爾多年份報告

這是熱浪肆虐的一年，酷暑和提早收割造就與別不同的紅酒。生長期初段一切如常，開花情況理想，預示能提早收割。但8月氣溫飆升至攝氏40度，遠高於波爾多一般大約攝氏34至35度的熱浪，因此令收成非常早熟，收割的葡萄極少，果實小而厚皮，酸度集中和熟透。

部分莊園的葡萄酒非常精彩，但部分則令人失望，整體而言仍然相當吸引。我嚐過該年份的多款出品，主要為2004年春季的期酒。

SUPERLATIVE VINTAGES OF RED AND WHITE BORDEAUX FROM A PRIVATE COLLECTOR ALL OFFERED IN ORIGINAL WOODEN CASES

The following lots 6164 to 6343 of superb vintages of red and white Bordeaux belong to a private collector who is delighted to be sharing a part of his collection of vinous treasures. The collection features exceptional drinking vintages from the world's premiere fine wine region of Bordeaux. The majority of the wines were bought *en primeur* in Bordeaux and were stored at Bordeaux City Bond until temperature and humidity controlled shipment to Hong Kong specifically for this sale. All the wines are offered in their original wooden cases and are in excellent conditions.

Château Cos d'Estournel 2003

Saint-Estèphe, 2ème cru classé

In original wooden cases

6164 12 bottles per lot HK\$12,000-18,000
6165 12 ..

Château Cos d'Estournel 2005

Saint-Estèphe, 2ème cru classé

In original wooden cases

6166 12 bottles per lot HK\$12,000-18,000
6167 12 ..
6168 12 ..

Château Lafite-Rothschild 1995

Pauillac, 1er cru classé

In banded original wooden cases

6169 12 bottles per lot HK\$35,000-55,000
6170 12 ..

Lots 6164-6168

Château Cos d'Estournel

A popular St. Estèphe producer in the northern reaches of the Médoc once making formidable, Cabernet Sauvignon-heavy blends. In recent years, the increasing use of Merlot has made the Grand Vin more accessible in youth, yet equally age-worthy. The 91-hectare estate is planted with 60% Cabernet Sauvignon and 40% Merlot.

Cos d'Estournel 是聖埃斯泰夫 (St. Estèphe) 的知名酒莊，位於梅鐸酒區北部，以往作品以卓越的赤霞珠 (Cabernet Sauvignon) 為主，近年來使用梅洛 (Merlot) 的比例越來越高，作品平易近人，適合新鮮品味，也可以長久收藏。

Château Lafite-Rothschild 1998

*Paulliac, 1er cru classé
In original wooden case*

6171 12 bottles per lot HK\$45,000-70,000

2004 BORDEAUX VINTAGE REPORT

A useful, agreeable, underrated and relatively reasonably priced vintage; these are wines for future drinking not investment. Careful selection is needed as by no means all the properties could afford the vital and expensive green-pruning and crop selection to avoid unripe grapes with raw tannins.

The weather was conducive; the flowering taking place in perfect conditions, even and speedy, the absence of coulure and millerandage ensuring a large crop and, all being well, an early harvest. The summer was warm, with refreshing showers. However August was very wet and temperature levels declined. A big crop of large bunches made full ripening and dilution a problem. Properties on the Left and Right Banks has similar successes - and failures, mainly due to the affordability of severe crop-thinning and selection. One thing is common: high tannin levels, the best soft, the last successful harsh. Michael Broadbent MW

2004年波爾多年份報告

此年份的出品味道宜人，價格相對合理，但被低估。因此，葡萄酒適合日後飲用，但並非投資之選。購入時需要小心挑選，謹記雖然摘去未成熟果實及篩選收成是關鍵的步驟，能避免來自未成熟果實的劣質單寧，但並非所有莊園也能負擔高昂的成本。

天氣有利葡萄生長，開花期在完美天氣下進行，均衡而迅速，沒有出現落果和果實大小不一的問題，保證收成豐盛，如無意外可提早收割。夏季溫暖，間中有雨，但8月非常潮濕，氣溫下降。大串葡萄豐收令果實未能完全成熟，攤薄養份。由於減少結果和篩選果實的成本問題，左右兩岸莊園的成敗情況也相若。但兩岸的共通之處是葡萄單寧含量高，其中上品的單寧柔順，下品則粗糙。



Château Lafite-Rothschild 2004

*Paulliac, 1er cru classé
In original wooden cases*

6172 6 magnums per lot HK\$40,000-60,000
6173 6 "
6174 6 "

2005 BORDEAUX VINTAGE REPORT

A vintage much heralded and achieving considerable acclaim from almost the moment the grapes were picked following well-nigh ideal growing conditions. The sort of year in which, unless the grower and winemaker were incompetent or suffered some misfortune, there was no excuse for making a poor wine.....

Before preparing my notes for publication, I was inclined to think that this was probably an over-hyped, overrated vintage. Having assembled them, however it is perfectly apparent that 2005 is unquestionably a vintage of the highest and, on the whole, most uniform quality. More than usual I have rated many wines 5 and 4-star; a few, in fact, hardly any, below 3-star. In short, thanks to the beneficial growing conditions and uniformly ripe grapes, sound winemaking and selection have made Bordeaux once again attractively drinkable - but at a price, not just at a high selling price but at the cost of individual character. In not 'all the same', there are insufficient contrasts. Too few faults and aberrations are, of course, welcome. But where is the drama, the excitement and undemonstrative finesse? Michael Broadbent MW

2005年波爾多年份報告

這是備受推崇的年份，生長條件近乎完美，在收割果實後已獲得相當好評。在這種理想的年份，除非葡萄農和釀酒師非常不濟或不幸，否則釀造出劣品的機會微乎其微。

在整理酒評前，我經常認為此年份被過份吹噓和高估，但整理後卻發現2005年顯然是頂尖的年份，整體上品質非常一致。我給予五星和四星的葡萄酒比平常更多，獲三星以下的寥寥無幾。簡而言之，由於生長條件理想和果實一致成熟，仔細的釀酒和挑選過程令波爾多再度成為可口的葡萄酒，但卻售價高昂，而且沒有突出的個性。於未算千篇一律的出品中，卻沒有明顯的對比。較少失手或偏差自然受人歡迎，但卻失去了那份驚喜、興奮和含蓄細膩。

Château Lafite-Rothschild 2005

*Paulliac, 1er cru classé
In banded original wooden cases*

6175 12 bottles per lot HK\$60,000-80,000
6176 12 "

Château Lafite-Rothschild 2006

*Paulliac, 1er cru classé
In banded original wooden cases*

6177 12 bottles per lot HK\$42,000-65,000
6178 12 "
6179 12 "
6180 12 "
6181 12 "

MIS EN BOUTEILLE AU CHATEAU



CHATEAU LAFITE ROTHSCHILD
2005
PAUILLAC



2008 BORDEAUX VINTAGE REPORT

This was a year when the vine was in no hurry to go anywhere, taking its time to bud, flower and ripen its grapes right through to the latest harvest since 1978. Like all late vintages, 1988, 1998 and 1978, the fruit character is of red rather than black fruit, but the similarity ends here, the 2008's having much more power and concentration than all of these, imparted by a sensationally fine September - October. Thus they have strong dark colours, a fullness of middle-weight and ripeness of tannin as well as all the freshness of these red fruits. Some are just beginning to show a nice balance now but most will require a few more years. The wines were put on the market in the midst of the banking crisis's second dip, and were consequently very fairly priced. Bill Blatch

2008年波爾多年份報告

這一年的葡萄穩步生長，按時發芽、開花和成熟，是1978年以來最遲收成的一年。與1988、1998和1978年一樣，紅葡萄的特質比黑葡萄更突出，但勁道和集中度方面卻更勝一籌，全因9月及10月的絕佳天氣所致。因此，葡萄酒色澤深邃，中度飽滿，單寧成熟，擁有紅葡萄的清新氣息。部分出品已非常均衡圓熟，但多數還需要陳化數年。葡萄酒推出市場之際正值金融危機後的第二個谷底，因此價格相當合理。

Château Lafite-Rothschild 2008

Pauillac, 1er cru classé

In banded original wooden cases

6182	1	impérial	per lot	HK\$35,000-50,000
6183	1	„		

Château Lafite-Rothschild 2008

Pauillac, 1er cru classé

In banded original wooden cases

6184	6	magnums	per lot	HK\$50,000-70,000
6185	6	„		

Château Lafite-Rothschild 2008

Pauillac, 1er cru classé

In banded original wooden cases

6186	12	bottles	per lot	HK\$50,000-70,000
6187	12	„		
6188	12	„		
6189	12	„		
6190	12	„		

Lots 6169-6190

焦溜丸子配 Château Lafite Rothschild

焦溜丸子是一道魯菜名肴，原料易得、烹飪簡單且不費時，因此是家庭聚餐的必備菜肴。要選取新鮮的五花肉，絞成肉泥，口感肥瘦相間。肉泥混上雞蛋清、料酒、蔥姜末、豆瓣醬，充分攪拌，這一步雖然簡單，但是卻是製作丸子的關鍵步驟。只有攪拌功夫做得足夠，才能使做出來的丸子彈牙脆口。旺火熱油炸至八分熟，丸子飄在油面上即可出鍋。然後用料酒、蔥、姜調羹汁，炸好的丸子在其中翻炒幾下即可出鍋。做好的焦溜丸子經過兩次油煎炸，外焦裡嫩，口感對比鮮明。波爾多左岸酒王拉菲，向來是搭配豬肉菜肴的最佳選擇。赤霞珠雄渾的結構和美樂豐腴的酒體，與這道丸子在一起口感搭配相當不錯。

乙未秋日，張脩翰。

Twice-Fried Meatballs and Château Lafite Rothschild

A classic dish in Shandong cuisine, twice-fried meatballs are regularly featured in family meals, as the ingredients are easily available and the cooking process is relatively straightforward. Fresh pork belly is finely minced to provide a balanced texture. Adding egg whites, cooking wine, fine scallion and ginger pieces with spicy bean sauce (*doubanjiang*), the minced meat is then rigorously mixed together with the marinade. This seemingly simple step is crucial in making good meatballs. Only well mixed mince can be cooked into succulent meatballs, likewise crispy on the outside. Raw meatballs are fried until medium-well in wok with heated frying oil which is just below the boiling point. The meatballs are ready when they are floating on the surface of the oil. After being removed from the oil, the meatballs are quickly stir-fried again in a sauce made with rice wine, scallion and ginger. Meatballs fried twice in this manner are crispy and delicately charred outside as well as juicy and tender inside. The king of the Bordeaux left bank, Château Lafite Rothschild, matches excellently with pork dishes. The pronounced structure of cabernet sauvignon and the rich body of merlot make the wine a great choice to pair with the meatballs.

Autumn 2015. Austin Zhang

Château Latour 2005*Pauillac, 1er cru classé
In original wooden cases*

6191	12 bottles	per lot	HK\$55,000-75,000
6192	12 "		

Château Latour 2006*Pauillac, 1er cru classé
In banded original wooden cases*

6193	12 bottles	per lot	HK\$35,000-50,000
6194	12 "		

Château Mouton Rothschild 2000*Pauillac, 1er cru classé
In original wooden cases*

6195	1 jeroboam	per lot	HK\$70,000-100,000
6196	1 "		

Château Mouton Rothschild 2003*Pauillac, 1er cru classé
In original wooden cases*

6197	12 bottles	per lot	HK\$30,000-45,000
6198	12 "		
6199	12 "		
6200	12 "		
6201	12 "		

Château Mouton Rothschild 2005*Pauillac, 1er cru classé
In banded original wooden cases*

6202	12 bottles	per lot	HK\$38,000-50,000
6203	12 "		

Lots 6195-6211

鍋塌豆腐配 Château Mouton Rothschild

鍋塌豆腐是一道經典的魯菜，隨著清末魯菜的流行已經傳遍全國。鍋塌的烹飪方法指鍋內放少量油，小火將掛糊的原料煎成兩面金黃色，在加湯汁調料小火收緊煨幹。做好的鍋塌豆腐色澤金黃、表面酥而內裡嫩，湯汁入味而口感豐富，可以嘗試搭配波爾多名莊木桐。木桐是經典的波爾多左岸混釀，採用高比例的赤霞珠，配以美樂、品麗珠和少許小味兒多調味。赤霞珠雄渾剛勁的結構和黑色漿果為主的香氣，非常適合用料豐富、口味鮮咸的魯菜。

張脩翰，乙未秋初。

Northern Style Fried Tofu and Château Mouton Rothschild

Northern Style Fried Tofu is a classic Shandong cuisine, whose popularity has spread all over China by the end of Qing Dynasty. To make the dish, one first heats up a small amount of oil, then fries the lightly battered tofu squares over low heat until golden on all sides. The tofu is then braised in a stock until the juice is reduced to a rich sauce. Well-cooked Northern Style Fried Tofu has a golden appearance, is crispy on the outside and juicy on the inside, accompanied by a scrumptious sauce. It can be nicely paired with a celebrated Mouton Rothschild, a classic Bordeaux left bank cru made with high percentage of Cabernet Sauvignon, complemented with Merlot, Cabernet Franc and a touch of Petit Verdot. The strong structure of the Cabernet Sauvignon and the blackberries scents are great match for the rich flavours of Shandong cuisine.

Autumn 2015. Austin Zhang.



Lots 6195-6196

Château Mouton Rothschild 2006*Pauillac, 1er cru classé**In banded original wooden cases*

6204	12 bottles	per lot	HK\$30,000-45,000
6205	12 "		
6206	12 "		
6207	12 "		
6208	12 "		
6209	12 "		
6210	12 "		
6211	12 "		

Château Pichon-Longueville, Lalande 2003*Pauillac, 2ème cru classé**In original wooden cases*

6212	12 bottles	per lot	HK\$9,000-13,000
6213	12 "		
6214	12 "		
6215	12 "		

Château Pichon-Longueville, Lalande 2004*Pauillac, 2ème cru classé**In original wooden cases*

6216	12 bottles	per lot	HK\$7,000-10,000
6217	12 "		
6218	12 "		

Château Pichon-Longueville, Lalande 2006*Pauillac, 2ème cru classé**Twelve bottles in original wooden cases*

6219	18 bottles	per lot	HK\$12,000-18,000
------	------------	---------	-------------------

Château Pontet-Canet 2003*Pauillac, 5ème cru classé**In original wooden cases*

6220	12 bottles	per lot	HK\$6,000-9,000
6221	12 "		
6222	12 "		

Lots 6212-6219

Château Pichon-Longueville, Lalande

Often considered a Super Second, Lalande is made in a softer style relative to its sister property across the street due to its higher percentage of Merlot. The second wine is called Réserve de la Comtesse.

Pichon Lalande 往往被視為超級二級酒莊。由於作品含有比例較高的梅洛 (Merlot)，與對街的姐妹莊園相較下，更顯溫柔婉約。其推出的二軍酒名為 Réserve de la Comtesse。

Château Pontet-Canet 2005*Pauillac, 5ème cru classé**In original wooden cases*

6223	12 bottles	per lot	HK\$8,500-13,000
6224	12 "		

Château Pontet-Canet 2006*Pauillac, 5ème cru classé**In original wooden cases*

6225	24 bottles	per lot	HK\$11,000-17,000
6226	24 "		
6227	24 "		
6228	24 "		

Lots 6220-6228

Château Pontet Canet

Though a 5th Growth in name, Pontet Canet is widely respected for making exemplary Pauillac and has enjoyed considerable renown in recent years - especially among wine insiders. Its other claim to fame is being the first Grand Cru Classé to be produced 100% biodynamically.

儘管 Pontet Canet 名列五級酒莊，卻每每締造傑出的波亞克名酒，廣受推崇。近年更因卓越的表現聲名大噪，獲得許多品酒師的高度評價。酒莊之所以大受歡迎的另一個原因，也是因為它是列級酒莊中，第一個百分之百採用自然動力種植法生產葡萄的酒庄。

Château Ducru-Beaucaillou 2003*Saint-Julien, 2ème cru classé**In original wooden cases*

6229	24 bottles	per lot	HK\$18,000-28,000
------	------------	---------	-------------------

Château Ducru-Beaucaillou 2006*Saint-Julien, 2ème cru classé**In original wooden cases*

6230	24 bottles	per lot	HK\$15,000-24,000
6231	24 "		
6232	24 "		

Château Léoville-Las-Cases 2003*Saint-Julien, 2ème cru classé**In original wooden cases*

6233	12 bottles	per lot	HK\$12,000-18,000
6234	12 "		
6235	12 "		
6236	12 "		
6237	12 "		

Lots 6233-6240

爆炒腰花配 Château Léoville-Las-Cases

腰花就是花刀切出來的動物腎臟，魯菜善用豬腰花烹飪，爆炒腰花是其中最具有代表性的菜着，也是魯菜酒家必備的看家菜之一。做好的腰花不但造型美觀，口感豐腴且不肥膩，鮮嫩可口。烹製時必須要選取最新鮮的豬腎，花刀切好後，放入醬油中醃制入味。為了提鮮，烹飪時往往搭配筍片、木耳等山珍。腰花貴在鮮嫩，炒制的工藝最為關鍵。需要先用熱油爆炒，迅即出鍋。然後文火烹飪料酒、澱粉、鹽、醬油調成的芡汁，再將預製好的腰花顛翻入味即可出鍋。魯菜往往與波爾多葡萄酒是絕配，這道魯菜最有代表性的腰花，選用左岸名莊雄獅莊最好不過。雄獅被羅伯特派克評為超二級莊，視為最有能力挑戰一級莊的不二之選，以其如雄獅般霸道粗曠的酒體著稱。霸氣的雄獅，搭配細膩爽口的腰花，可以算是魯菜與波爾多葡萄酒的完美聯姻。

乙未秋日，張翰翰。

Stir-fried Kidney and Château Léoville-Las-Cases

In Chinese dishes, kidneys are often prepared with elaborate crisscross cut to give the offal a beautiful appearance, transforming them into *yaohua*, literally 'kidney flowers'. Shandong cuisine makes frequent use of pork kidneys and this dish is one of the most representative of the region's fare, which is a must have in every Shandong restaurants. Kidneys prepared in this manner are not only delicate, but also extremely tender, moist and not greasy at all. The freshest pork kidneys must be selected to make this dish. After crisscross cutting the kidney surfaces, they are then marinated with soy sauce. Bamboo shoots and black mushrooms are often added as accompaniment to enrich the flavour. The succulent texture of the kidneys is the soul of this dish, therefore ingenious stir-frying skills are essential. Usually kidneys are quickly stir-fried in hot oil, then swiftly removed from the heat and sautéed again in a sauce slowly cooked from cooking wine, starch, salt and soy sauce to boost the flavour. Shandong cuisine is often best paired with Bordeaux wines. This typical kidney dish goes extremely well with the famous Château Léoville Las Cases of the Bordeaux left bank. Château Léoville Las Cases is classed by Robert Parker as a Super Second Bordeaux winemaker, and is widely considered a certain choice to challenge Premier Cru vineyards. The wine produced by the Château is known for its powerful structure and full body, reminiscent of the strength of a lion. The majestic lion and the delicate, crispy kidney is a match made in heaven between Bordeaux wine and Shandong cuisine.

Autumn 2015. Austin Zhang



Lots 6233-6240

Château Léoville-Las-Cases 2006

Saint-Julien, 2ème cru classé

In original wooden cases

6238	12 bottles	per lot	HK\$10,000-15,000
6239	12 "		
6240	12 "		

Château Margaux 2005

Margaux, 1er cru classé

In banded original wooden cases

6241	12 bottles	per lot	HK\$45,000-65,000
6242	12 "		

2006 BORDEAUX VINTAGE REPORT

This was a vintage that got off to a tremendous start with an efficient flowering followed by a hot and dry June - July, rather similar to 1995. At this stage, we thought we would be in for another rich and powerful wine. Then August was a bit of a lost month, wet and cool. There was little detrimental effect on the grapes but it shaped the vintage's potential character from something potentially very rich into something tighter and more "classic". A fine September quickly ripened the fruit but there were showers just before and during harvest, which just hardened up the tannins in the final stages and added to the tightly-wound style of the vintage. So the wines, whilst beautifully ripe, have a tannic edge to them that will take a few more years to shake off. This is a true blue Bordeaux vintage, all tightness and tautness, reserved rather than flamboyant, with similarities to, but considered better than, the '66 and '88. Some can be drunk with pleasure already but most will be better after another decade or so. Bill Blatch

2006年波爾多年份報告

此年份起步絕佳，開花期順暢，隨後6月及7月天氣炎熱乾燥，與1995年類似。當時大家以為能再度釀出豐沛剛勁的葡萄酒。但8月潮濕涼爽，未如理想，雖然對果實沒有太大影響，卻削弱了令此年份的潛力，變得更集中濃厚、更傳統。9月晴朗天氣令葡萄迅速成熟，但收割前和期間下雨，令單寧在最後階段變硬，令酸度更集中。儘管果實成熟，葡萄酒卻帶有濃重的單寧，需要陳化數年才能散去。這是典型的沉鬱波爾多紅酒，濃厚集中，含蓄內斂，與1966年及1988年相似，但稍佳。一部分出品已可以開瓶享用，但大部分最好再陳年十年以上。

Château Margaux 2006

*Margaux, 1er cru classé
In banded original wooden cases*

6243	12 bottles	per lot	HK\$30,000-45,000
6244	12 "		
6245	12 "		
6246	12 "		
6247	12 "		

Château Lascombes 2004

*Margaux, 2ème cru classé
In original wooden cases*

6248	24 bottles	per lot	HK\$10,000-15,000
6249	24 "		
6250	24 "		

Château Lascombes 2005

*Margaux, 2ème cru classé
In original wooden cases*

6251	24 bottles	per lot	HK\$14,000-22,000
6252	24 "		
6253	24 "		

Château Haut-Brion 2003

*Pessac (Graves), 1er cru classé
In original wooden cases*

6254	12 bottles	per lot	HK\$24,000-35,000
6255	12 "		

Château Haut-Brion 2003

*Pessac (Graves), 1er cru classé
Six in six-bottle original wooden case, two in individual wooden cases. Four stained labels*

6256	12 bottles	per lot	HK\$24,000-35,000
------	------------	---------	-------------------

Château Haut-Brion 2004

*Pessac (Graves), 1er cru classé
In original wooden cases*

6257	12 bottles	per lot	HK\$22,000-32,000
6258	12 "		
6259	12 "		
6260	12 "		
6261	12 "		
6262	12 "		

Château Haut-Brion 2005

*Pessac (Graves), 1er cru classé
In original wooden case*

6263	12 bottles	per lot	HK\$42,000-65,000
------	------------	---------	-------------------

Château Haut-Brion 2006

*Pessac (Graves), 1er cru classé
In original wooden cases*

6264	12 bottles	per lot	HK\$24,000-35,000
6265	12 "		
6266	12 "		
6267	12 "		
6268	12 "		

Château La Mission-Haut-Brion 2005

*Pessac (Graves), cru classé
In original wooden cases*

6269	12 bottles	per lot	HK\$30,000-45,000
------	------------	---------	-------------------

Château La Mission-Haut-Brion 2006

*Pessac (Graves), cru classé
In original wooden cases*

6270	12 bottles	per lot	HK\$14,000-22,000
6271	12 "		
6272	12 "		



Lots 6269-6272

Château Pape-Clément Rouge 2005

In original wooden cases

6273 12 bottles *per lot* HK\$20,000-30,000

6274 12 „

Lots 6273-6274

Château Pape-Clément

One of its many claims to fame is as the oldest wine estate in Bordeaux, harvesting its 700th vintage in 2006. A much more recent accomplishment is the estate's 2010 vintage effort receiving a perfect 100 pointer from wine critic Robert Parker. The estate also produces a dry white wine from vineyards planted with 45% Sauvignon Blanc, 45% Sémillon, 5% Muscadelle and 5% Sauvignon Gris.

Pape-Clément 夙負盛名，亦是波爾多酒區歷史最悠久的酒莊，2006 年曾推出過七百款年份佳作。2010 年的作品甚至獲得品酒師羅伯·帕克 (Robert Parker) 一百分的完美評價，堪稱近年來最輝煌的成就。

Petrus 1982

Pomerol, cru exceptionnel

In original wooden case. Slightly damaged capsules.

Three slightly depressed corks. Levels into neck

6275 6 bottles *per lot* HK\$120,000-180,000

Le Pin 2004

Pomerol

In three-bottle original wooden cases

6276 6 bottles *per lot* HK\$65,000-95,000

Le Pin 2004

Pomerol

In three-bottle original wooden cases

6277 12 bottles *per lot* HK\$130,000-190,000

Château Clos L'Eglise 2004

Pomerol

In six-bottle original wooden cases

6278 24 bottles *per lot* HK\$9,000-14,000

6279 24 „

6280 24 „



Lots 6282-6284

Château Clos L'Eglise 2004

Pomerol

In six-bottle original wooden cases

6281 36 bottles *per lot* HK\$14,000-22,000

Château L'Eglise Clinet 2006

In original wooden cases

6282 12 bottles *per lot* HK\$12,000-18,000

6283 12 „

6284 12 „

Lots 6282-6284

Château L'Eglise Clinet

Its history dates back to the 1950's, when vineyards originally belonging to Château Clinet and Château Clos L'Eglise were combined to create this new estate. It is planted to a typical mixture of 80% Merlot and 20% Cabernet Franc.

L' Eglise Clinet 酒莊歷史可追溯至 1950 年代，當時的葡萄園原本由 Château Clinet 及 Château Clos L' Eglise 兩家酒莊所有，後來合而為一，成為現今的 L' Eglise Clinet。當地生產的葡萄有 80% 是梅洛 (Merlot)，20% 為品麗珠 (Cabernet Franc)。

Château L'Évangile 2005

Pomerol

In original wooden case

6285 12 bottles per lot HK\$15,000-24,000

Château Trotanoy 2004

Pomerol

In six-bottle original wooden cases

6286 24 bottles per lot HK\$16,000-24,000

6287 24 "

6288 24 "

6289 24 "

Lots 6286-6289

上湯豌豆苗配 Château Trotanoy

制湯又被稱作吊湯，是中國菜烹飪基本功之一。主要的原理就是將雞、鴨、牛肉、排骨、菌菇等動植物原料在水中長時間煮沸、熬制，以充分萃取其中蛋白質、脂肪和其他鮮味物質溶于水中，是重要的提味增香技藝。上湯豌豆苗一般使用雞湯，如果做素菜也可以用豆芽或者菌菇做素湯。豌豆苗吃的就是鮮嫩，不但要選去最為新鮮的原料，備菜的時候也要把根部老的部分掐掉。而上湯菜除了上湯和原料，最重要的就是蒜煸。熱油煸出蒜香，再加火腿、皮蛋丁、草菇提味，就可以加入上湯了，豌豆苗略微一氽即可出鍋，否則就會過老。可以搭配波爾多右岸波美侯地區的傳統名莊 Chateau Trotanoy，使用高比例的美樂葡萄，口感豐腴，香氣濃郁，與鮮嫩的豆苗和濃厚的上湯搭配極佳。

乙未秋日，張脩翰。

Château Angéus 2005

Saint-Émilion, grand cru classé

In original wooden cases

6290 12 bottles per lot HK\$22,000-35,000

6291 12 "

Château Cheval-Blanc 2004

Saint-Émilion, 1er grand cru classé (A)

In original wooden cases

6292 12 bottles per lot HK\$22,000-35,000

Lots 6290-6291

生煎饅頭配 Château Angéus

生煎饅頭(生煎)是上海傳統早餐必備之一，配上一碗油豆腐線粉湯，可以算是經典了。不同的肉餡配上肉皮凍裹在麵團裡，煎過後肉質鮮嫩而又湯水充足。可以試一下用聖埃米利永的金鐘搭配一下上海的生煎，感受一下金鐘絲滑的質感如何與生煎湯汁的餘味交織在一起。隨著 007 在 Skyfall 中造訪上海，不知道特工先生會不會嘗試一下生煎包配他最愛的金鐘呢？

張脩翰，2013 年 4 月

Pan-fried Bun with Château Angéus

Pan-fried Bun is a specialty of traditional Shanghai breakfast and would be classic when paired with fried bean curd soup. Stuffed with pork and gelatine, they melt into a soup when fried, making it succulent and appetizing. Try a bottle of Château Angéus to feel the silky texture of the wine incorporated with the lingering finish of the soup in the bun. Having visited Shanghai in the film Skyfall, will James Bond try Pan-fried Bun with his favourite Angéus?

Austin Zhang, April 2013

Château Cheval-Blanc 2005

Saint-Émilion, 1er grand cru classé (A)

In original wooden cases

6293 12 bottles per lot HK\$40,000-55,000

6294 12 "

Château Cheval-Blanc 2006

Saint-Émilion, 1er grand cru classé (A)

In original wooden cases

6295 12 bottles per lot HK\$24,000-38,000

6296 12 "

6297 12 "

6298 12 "

Château Pavie 2005*Saint-Emilion, 1er grand cru classé**In original wooden cases*

6299	12 bottles		per lot	HK\$24,000-35,000
6300	12	"		
6301	12	"		
6302	12	"		
6303	12	"		

Château Pavie 2006*Saint-Emilion, 1er grand cru classé**In original wooden cases*

6304	12 bottles		per lot	HK\$16,000-24,000
6305	12	"		
6306	12	"		
6307	12	"		
6308	12	"		

Château La Mondotte 2006*Saint-Emilion, grand cru classé**In six-bottle original wooden cases*

6309	12 bottles		per lot	HK\$12,000-18,000
6310	12	"		

Château Monbousquet 2005*Saint-Emilion, grand cru**In original wooden cases*

6311	24 bottles		per lot	HK\$12,000-18,000
6312	24	"		
6313	24	"		
6314	24	"		

Château Rol Valentin 2003*Saint-Emilion, grand cru classé**In original wooden cases*

6315	36 bottles		per lot	HK\$11,000-17,000
6316	36	"		
6317	36	"		

Château Valandraud 2003*Saint-Emilion, grand cru classé**In original wooden cases*

6318	24 bottles		per lot	HK\$18,000-28,000
6319	24	"		

Coffret Bordeaux Collection 2006

2006 Château Lafite-Rothschild	(1)
2006 Château Latour	(1)
2006 Château Mouton Rothschild	(1)
2006 Château Margaux	(1)
2006 Château Haut-Brion	(1)
2006 Château La Mission-Haut-Brion	(1)
2006 Château Petrus	(1)
2006 Château Cheval-Blanc	(1)
2006 Château d'Yquem	(1)

In banded original wooden case

6320	Above 9 bottles		per lot	HK\$30,000-45,000
------	-----------------	--	---------	-------------------

Coffret Corndale Collection 2008

2008 Château Lafite-Rothschild	(1)
2008 Château Latour	(1)
2008 Château Mouton Rothschild	(1)
2008 Château Margaux	(1)
2008 Château Haut-Brion	(1)
2008 Château Petrus	(1)
2008 Château Lafleur	(1)
2008 Le Pin	(1)
2008 Château Cheval-Blanc	(1)
2008 Château Pavie	(1)
2008 Château Ausone	(1)
2008 Château d'Yquem	(1)

In original wooden cases

6321	Above 12 bottles		per lot	HK\$45,000-70,000
6322	Above 12	"		

Coffret Prestige Collection 2005

2005 Château Lafite-Rothschild	(1)
2005 Château Latour	(1)
2005 Château Mouton Rothschild	(1)
2005 Château Margaux	(1)
2005 Château Petrus	(1)
2005 Château Cheval-Blanc	(1)

In original wooden cases

6323	Above 6 bottles		per lot	HK\$40,000-60,000
6324	Above 6	"		

Château d'Yquem 2003*Sauternes, 1er grand cru classé**In banded original wooden cases*

6325	12 bottles		per lot	HK\$12,000-18,000
6326	12	"		
6327	12	"		
6328	12	"		
6329	12	"		
6330	12	"		
6331	12	"		

Château d'Yquem 2004*Sauternes, 1er grand cru classé**In banded original wooden cases*

6332	12 bottles	per lot	HK\$12,000-18,000
6333	12 "		
6334	12 "		
6335	12 "		
6336	12 "		
6337	12 "		

Château d'Yquem 2005*Sauternes, 1er grand cru classé**In banded original wooden cases*

6338	12 bottles	per lot	HK\$16,000-26,000
6339	12 "		

Château d'Yquem 2006*Sauternes, 1er grand cru classé**In banded original wooden cases*

6340	12 bottles	per lot	HK\$15,000-24,000
6341	12 "		
6342	12 "		

Lots 6325-6342

蜜三刀配 d'Yquem

不但可以作為菜點和零食，也可以當作餐後甜點，可能很多人感覺這樣甜的發膩的東西可能很難搭配葡萄酒，實則不然，你可以嘗試一下滴金，雖然同樣甜度很高，但是其中的酸味巧妙地中和的甜味帶來的膩感。在一場大餐的最後，這樣的搭配想必是完美的收場吧？

張偉翰，2013年4月

Fried Cake Glazed in Malt Sugar with d'Yquem

This fried cake can not only be served as a snack or with tea, but also as a dessert. People might find it difficult to pair something so sweet with wine; however this is a perfect match. Château d'Yquem has high levels of residual sugar, but the acidity balances perfectly with the sweetness. After a long and delicious meal, wouldn't this be the perfect ending with this pairing?

Austin Zhang, April 2013

Château Doisy Daëne Extravagant 2005*In individual original wooden cases*

6343	24 half-bottles	per lot	HK\$15,000-24,000
------	-----------------	---------	-------------------

**DUCLOT ASSORTMENT CASES 2004 TO 2010
FROM A PRIVATE COLLECTOR****Duclot Collection**

2004 Château Lafite-Rothschild	(1)
2004 Château Latour	(1)
2004 Château Mouton Rothschild	(1)
2004 Château Margaux	(1)
2004 Château Haut-Brion	(1)
2004 Château La Mission-Haut-Brion	(1)
2004 Château Petrus	(1)
2004 Château Cheval-Blanc	(1)
2004 Château d'Yquem	(1)

In banded original wooden case

6344	Above 9 bottles	per lot	HK\$35,000-55,000
------	-----------------	---------	-------------------

Duclot Collection

2005 Château Lafite-Rothschild	(1)
2005 Château Latour	(1)
2005 Château Mouton Rothschild	(1)
2005 Château Margaux	(1)
2005 Château Haut-Brion	(1)
2005 Château La Mission-Haut-Brion	(1)
2005 Château Petrus	(1)
2005 Château Cheval-Blanc	(1)
2005 Château d'Yquem	(1)

In banded original wooden case

6345	Above 9 bottles	per lot	HK\$60,000-90,000
------	-----------------	---------	-------------------

Duclot Collection

2006 Château Lafite-Rothschild	(1)
2006 Château Latour	(1)
2006 Château Mouton Rothschild	(1)
2006 Château Margaux	(1)
2006 Château Haut-Brion	(1)
2006 Château La Mission-Haut-Brion	(1)
2006 Château Petrus	(1)
2006 Château Cheval-Blanc	(1)
2006 Château d'Yquem	(1)

In original wooden case. Banded prior to inspection

6346	Above 9 bottles	per lot	HK\$40,000-60,000
------	-----------------	---------	-------------------

Duclot Collection

2008 Château Lafite-Rothschild	(1)
2008 Château Latour	(1)
2008 Château Mouton Rothschild	(1)
2008 Château Margaux	(1)
2008 Château Haut-Brion	(1)
2008 Château La Mission-Haut-Brion	(1)
2008 Château Petrus	(1)
2008 Château Cheval-Blanc	(1)
2008 Château d'Yquem	(1)

In banded original wooden case

6347	Above 9 bottles	per lot	HK\$45,000-70,000
------	-----------------	---------	-------------------

Duclot Collection

- 2009 Château Lafite-Rothschild (1)
- 2009 Château Latour (1)
- 2009 Château Mouton Rothschild (1)
- 2009 Château Margaux (1)
- 2009 Château Haut-Brion (1)
- 2009 Château La Mission-Haut-Brion (1)
- 2009 Château Petrus (1)
- 2009 Château Cheval-Blanc (1)
- 2009 Château d'Yquem (1)

In original wooden case. Banded prior to inspection

6348 Above 9 bottles per lot HK\$70,000-110,000

Duclot Collection

- 2010 Château Lafite-Rothschild (1)
- 2010 Château Latour (1)
- 2010 Château Mouton Rothschild (1)
- 2010 Château Margaux (1)
- 2010 Château Haut-Brion (1)
- 2010 Château La Mission-Haut-Brion (1)
- 2010 Château Petrus (1)
- 2010 Château Cheval-Blanc (1)
- 2010 Château d'Yquem (1)

In banded original wooden case

6349 Above 9 bottles per lot HK\$70,000-110,000

CHÂTEAU LATOUR

Château Latour is situated in the heart of the Médoc wine region, about 50 km north-west of Bordeaux, where the legend of the vineyards of Bordeaux began. The Château's prime terroir, l'Enclos, overlooks the estuary of the Gironde river which, over the centuries, has given the vineyard its geological complexity and, on a daily basis, ensures a mild climate.

Most of Château Latour's vines are planted on gravelly hilltops that stand 12 to 16 meters above the Gironde estuary. The fortunate combination of the Gironde, layers of gravel on the surface and clay subsoil gives Château Latour's terroir advantages that few other vineyards can claim. The vineyard currently consists of 90 hectares in production; it is the grapes from the 47 hectares that surround the Château, known as l'Enclos that may potentially be used in the production of the Grand Vin. The estate is planted with about 80% of Cabernet Sauvignon, 18% of Merlot and 2% of Cabernet Franc and Petit Verdot.

In the years since 1993, under the leadership of François Pinault and his family, the estate's owners, significant changes have been made with a view to maintaining Château Latour's pursuit of excellence in the wines that it produces.

In 1998, Frédéric Engerer, who joined the estate early in 1995, was appointed President. Major works started in November 1999 and continued until September 2003. A total renovation of the winery, vat room, wine making facilities and storage areas enabled even greater precision in the production of the wines. A new technical team was also created.

The 90 hectares of the estate are locally managed by Frédéric Engerer and his team. Today, the men and women working at Château Latour in the vineyard and in the cellar are motivated by a search of perfection. Numerous experiments are continuously being carried out in order to judge the suitability of new procedures. This might for example involve biodynamic methods or new traceability systems, their quest is always for precision, quality and awareness of new issues.



拉圖

位處梅多克產區核心的拉圖莊，距離波爾多西北部約 50 公里，是波爾多葡萄酒傳奇開端的開端。當中，朗洛擁有酒莊的黃金風土，這裡俯瞰吉倫特河口，全年氣候溫和，世代以來一直賦予葡萄園層次豐富的地質結構。

拉圖莊的大部分葡萄樹種植於吉倫特河口 12 至 16 米以上的砂礫山峰。吉倫特的土壤由砂礫表層和粘土底層組成，這個有利組合為拉圖莊帶來無與倫比的風土，在其他葡萄園中實屬罕見。酒莊目前佔地 90 公頃，而環繞莊園的 47 公頃葡萄田名為朗洛，不少釀製一級酒的葡萄正是由此採摘。酒莊種植近 80% 的赤霞珠，另外 18% 是美樂，餘下的 2% 為品麗珠和小味兒。

自 1993 年在酒莊擁有人弗朗索瓦·皮諾 (François Pinault) 及其家人的帶領下，拉圖有了顯著的轉變，藉以秉持酒莊力求卓越的釀酒精神。

弗雷德里克·恩格瑞 (Frédéric Engerer) 在 1995 年初加入莊園，至 1998 年獲任命為總裁。1999 年 11 月，主要改革正式展開，一直到 2003 年 9 月。期間，酒廠、發酵間、釀酒設施和儲存庫均經全面整修，令葡萄酒的生產過程更為精確。新技術團隊亦相繼成立。

面積達 90 公頃的酒莊由弗雷德里克·恩格瑞和他的團隊合力管理。如今，拉圖莊的葡萄園和酒窖員工上下一心，力求盡善盡美。各人進行了一次又一次的實驗，從而判斷新程序是否合用，當中包括涉及生物動力學的方法或最新追蹤系統，他們竭力追求精準表現和優秀品質，並時刻關注新事物。



Lots 6350-6351

RARE CHATEAU LATOUR INCLUDING 1858 & 1861 & A VERTICAL FROM 1894 TO 2008 FROM A PRIVATE COLLECTOR

The following lots 6350 to 6367 of fine and rare vintages of Château Latour are from a European private collector. Of particular note are the exceedingly rare vintages of 1858 and 1861 that the current vendor received direct from the cellars of Château Latour in the late 1990's and have been reconditioned by the Château and are in outstanding condition and very rarely seen at auction. Another highlight is the vertical collection from 1894 to 2008 that is presented in ten custom-made wooden presentation cases; ten vintages per case.

拉圖珍罕私人窖藏，匯集 1858 年和 1861 年佳釀以及 1894 年至 2008 年之垂直系列

下列拍品 6350 至 6367 全屬拉圖莊的珍稀佳釀，來自一名歐洲私人藏家。焦點落於極其罕見的 1858 年和 1861 年，由現任藏家於 1990 年代後期直接從拉圖酒窖購入，並經酒莊翻新，狀態良好，在拍賣場上更是難得一見。另一亮點為 1894 年至 2008 年的垂直系列，分別藏置於十個特別訂製的木盒內，每個木盒藏有十瓶年份佳釀。

Château Latour 1858

Pauillac, 1er cru classé

Received by the vendor directly from Château Latour's private cellar in 1999. Reconditioned by Château. Recent capsule. Depressed cork. Good label. Level base of neck

6350 1 bottle *per lot* HK\$80,000-120,000

Château Latour 1861

Pauillac, 1er cru classé

Received by the vendor directly from Château Latour's private cellar in 1999. Reconditioned by Château. Slightly damaged Recent capsule. Good label. Level into of neck

6351 1 bottle *per lot* HK\$40,000-80,000

Château Latour 1882

Pauillac, 1er cru classé

Corroded, faded, damaged original capsule. Very badly damaged label. Level mid-low shoulder

6352 1 bottle *per lot* HK\$10,000-15,000

Château Latour 1887

Pauillac, 1er cru classé

Damaged capsule. Slightly stained label. Red typewritten vintage. Level top-shoulder

6353 1 bottle *per lot* HK\$20,000-40,000

Château Latour 1888
Pauillac, 1er cru classé
Slightly damaged capsule. Slightly stained label. Red typewritten vintage. Level just below top-shoulder on flat shouldered bottle
 6354 1 bottle per lot HK\$20,000-40,000

Château Latour 1891
Pauillac, 1er cru classé
Slightly damaged capsule. Slightly stained label. Red typewritten vintage. Level into neck
 6355 1 bottle per lot HK\$10,000-15,000

Mixed 1900s Château Latour

1901 Château Latour (1)
Slightly damaged recent capsule. Stained label. Black typewritten vintage. Level top-shoulder
1905 Château Latour (1)
Damaged recent capsule. Badly stained label. Red typewritten vintage. Level top-shoulder
1908 Château Latour (1)
Damaged recent capsule. Protruding cork. Slightly stained label. Faded black typewritten vintage. Level top-shoulder
 6356 Above 3 bottles per lot HK\$28,000-48,000

Mixed 1910s Château Latour

1910 Château Latour (1)
Recent capsule. Slightly depressed cork. Slightly stained label. Level upper-shoulder
1911 Château Latour (1)
Recent capsule. Depressed cork. Level top-shoulder
1912 Château Latour (1)
Damaged original capsule. Protruding cork. Stained and damaged label. Level mid-upper shoulder
1917 Château Latour (1)
Cut and damaged plain metal capsule, non-branded cork. Red typewriter vintage. Stained label. Level into neck
 6357 Above 4 bottles per lot HK\$24,000-40,000

Mixed 1920s Château Latour

1928 Château Latour (1)
Slightly damaged original capsule. Danish import slip label. Slightly stained and slightly damaged label. Level mid-upper shoulder
1929 Château Latour (1)
Corroded original capsule. Slightly stained label. Level low-shoulder
 6358 Above 2 bottles per lot HK\$32,000-65,000

Mixed 1930s Château Latour

1931 Château Latour (1)
Slightly damaged original capsule. Stained and damaged label. Level upper-shoulder
1933 Château Latour (1)
Bought in Christie's London in December 1992. Badly damaged original capsule. Very badly damaged label. Vintage illegible. Level upper-shoulder
1934 Château Latour (1)
Damaged original capsule. Protruding cork. Stained and damaged label. Level mid-upper shoulder
1935 Château Latour (1)
Badly corroded original capsule. Stained and damaged label. Level mid-shoulder
1938 Château Latour magnum (1)
Corroded recent capsule. Slightly stained label. Level upper-shoulder
1939 Château Latour (1)
Bought in Christie's London in September 1989. No capsule. Slightly stained and slightly damaged label. Level top-shoulder
 6359 Above 1 magnum and 5 bottles per lot HK\$48,000-75,000

Mixed 1940s Château Latour

1940 Château Latour (1)
Slightly damaged recent capsule. Wine stained label. Danish import slip label. Level mid-upper shoulder
1942 Château Latour (1)
Slightly damaged original capsule. Stained and damaged faded label. Handwritten vintage 1942 on label. Danish import slip label. Level upper-shoulder
1948 Château Latour half-bottle (1)
Slightly damaged original capsule. Badly stained label. Level mid-low shoulder
1949 Château Latour (1)
Corroded original capsule. Stained and slightly damaged label. Level mid-low shoulder
 6360 Above 3 bottles and 1 half-bottle per lot HK\$19,000-30,000

Mixed 1950s Château Latour

1950 Château Latour (1)
Corroded original capsule. Stained and damaged label. Level upper shoulder
1951 Château Latour (1)
Stained label. Danish import slip label. Level mid-low shoulder
1952 Château Latour (1)
Slightly damaged capsule. Wine stained label. Danish import slip label. Level upper-shoulder
1956 Château Latour magnum (1)
Slightly damaged original capsule. Slightly stained and slightly damaged label. Level top-shoulder
1957 Château Latour (1)
Damaged original capsule. Badly wine stained and damaged label. Level upper-shoulder
 6361 Above 1 magnum and 4 bottles per lot HK\$22,000-35,000

Mixed 1960s Château Latour**1962 Château Latour** (3)*Slightly damaged capsules. Badly wine stained labels
Two Danish import slip labels and one detached
Danish import slip label. Levels two top-shoulder, one
mid-shoulder***1963 Château Latour** (1)*Slightly damaged capsule. Badly wine stained label.
Danish import slip label. Level low-shoulder***1965 Château Latour** (1)*Slightly damaged capsule. Badly wine stained and
damaged label. Danish import slip label. Level upper-
shoulder***1968 Château Latour** (1)*Slightly damaged capsule. Wine stained and damaged
label. Detached Danish import slip label. Level top-
shoulder*

6362 Above 6 bottles per lot HK\$14,000-24,000

Mixed 1970s Château Latour**1970 Château Latour** (2)*One slightly corroded capsule. One very slightly
stained and one slightly stained labels. Danish import
slip labels. Levels upper-shoulder***1975 Château Latour** (3)*One depressed cork. One badly wine stained label and
two very slightly stained labels. Two Danish import slip
labels. Levels top-shoulder***1976 Château Latour** (1)*Creased and slightly stained label. Level top-shoulder***1977 Château Latour** (1)*Badly wine stained label. Danish import slip label.
Level top-shoulder***1979 Château Latour** (1)*Stained label. Danish import slip label. Level base of
neck*

6363 Above 8 bottles per lot HK\$14,000-24,000

Mixed 1980s Château Latour**1983 Château Latour** (2)*Danish import slip labels. Levels into neck***1985 Château Latour** (1)*Very slightly stained label. Danish import slip label.
Level base of neck***1987 Château Latour** (1)*Level very top-shoulder*

6364 Above 4 bottles per lot HK\$8,500-13,000

Mixed 1990s Château Latour**1990 Château Latour** (1)*Danish import slip label. Level base of neck***1992 Château Latour** (1)*Slightly stained and slightly damaged label. Danish
import slip label. Level into neck***1995 Château Latour** (1)*Slightly stained label. Level into neck***1996 Château Latour** (3)*Levels into neck***1997 Château Latour** magnum (1)*Slightly stained label. Level into neck*

6365 Above 1 magnum and 6 bottles per lot HK\$22,000-35,000

Mixed 2000s Château Latour**2000 Château Latour** (1)**2002 Château Latour** (1)**2004 Château Latour** (1)

6366 Above 3 bottles per lot HK\$9,000-13,000

Château Latour Vertical Collection 1894 - 2008**1894 Château Latour** (1)*Slightly damaged capsule. Stained label. Red
typewritten vintage. Level into neck***1896 Château Latour** (1)*Slightly damaged capsule. Slightly stained label.
Red typewritten vintage. Level into neck***1900 Château Latour** (1)*Slightly damaged capsule. Slightly protruding cork.
Slightly stained label. Red typewritten vintage.**Level base of neck***1901 Château Latour** (1)*Cut capsule. Faded black typewritten vintage.**Level base of neck***1904 Château Latour** (1)*Corroded and slightly damaged capsule. Slightly
protruding cork. Stained label. Faded black
typewritten vintage. Level into neck***1905 Château Latour** (1)*Creased and cut capsule. Stained and slightly
damaged label. Faded black typewritten vintage.**Level base of neck***1907 Château Latour** (1)*Slightly stained label. Faded black typewritten vintage.
Level base of neck***1908 Château Latour** (1)*Stained label. Red typewritten vintage. Level into neck***1909 Château Latour** (1)*Slightly damaged capsule. Slightly stained label.
Faded black typewritten vintage. Level into neck***1910 Château Latour** (1)*Reconditioned by Chateau in 1993. Very slightly
damaged label. Level into neck***1911 Château Latour** (1)*Protruding cork. Stained label. Red typewritten
vintage. Level into neck*

- 1913 Château Latour** (1)
Recent capsule. Discoloured and slightly stained label. Level base of neck
- 1914 Château Latour** (1)
Slightly stained label. Black typewritten vintage. Level base of neck
- 1916 Château Latour** (1)
Creased capsule. Slightly protruding cork. Slightly stained and slightly damaged label. Black typewritten vintage. Level into neck
- 1917 Château Latour** (1)
Cut plain metal capsule. Stained label. Faded black typewritten vintage. Level mid-upper shoulder
- 1918 Château Latour** (1)
Cut Recent capsule. Slightly stained label. Level base of neck
- 1920 Château Latour** (1)
Original short capsule. Stained and slightly damaged label. Level top-shoulder
- 1921 Château Latour** (1)
Corroded original short capsule. Badly stained and slightly damaged label. Level mid-shoulder
- 1922 Château Latour** (1)
Reconditioned by Château in 1989. Excellent appearance. Level into neck
- 1923 Château Latour** (1)
Faded and slightly damaged original short capsule. Badly stained and damaged label. Level mid-shoulder
- 1924 Château Latour** (1)
Original short capsule. Recorded in 1966. Stained and slightly damaged label. Level mid-upper shoulder
- 1925 Château Latour** (1)
Slightly corroded original short capsule. Slightly stained label. Level upper-shoulder
- 1926 Château Latour** (1)
Faded and slightly damaged original short capsule. Badly stained and slightly damaged label. Level mid-upper shoulder
- 1928 Château Latour** (1)
Recent capsule. Slightly stained label. Level base of neck
- 1929 Château Latour** (1)
Slightly damaged recent capsule. Slightly stained label. Level base of neck
- 1930 Château Latour** (1)
Reconditioned by Château in 1990. Level mid-shoulder
- 1931 Château Latour** (1)
Slightly damaged original short capsule. Stained and slightly damaged label. Level just below top-shoulder
- 1934 Château Latour** (1)
Original short capsule. Slightly depressed cork. Recent label. Excellent appearance. Level into neck
- 1935 Château Latour** (1)
Slightly damaged original short capsule. Slightly stained and slightly damaged label. Level mid-shoulder



VINTAGES

1959 - 1960 - 1961 - 1962 - 1963

1964 - 1965 - 1966 - 1967 - 1968





GRAND VIN
DE
CHATEAU LATOUR
PREMIER GRAND CRU CLASSE
APPELLATION PAUILLAC CONTROLEE
PAUILLAC-MEDOC
1949
MIS EN BOUTEILLES AU CHATEAU
MAISON FONDÉE EN 1765
SOCIÉTÉ CIVILE DU VIGNOBLE DE CHATEAU LATOUR
PROPRIÉTAIRE À PAUILLAC-GIRONDE

GRAND VIN
DE
CHATEAU LATOUR
PREMIER GRAND CRU CLASSE

GRAND VIN
DE
CHATEAU LATOUR
PREMIER GRAND CRU CLASSE

GRAND VIN
DE
CHATEAU LATOUR
PREMIER GRAND CRU CLASSE
PAUILLAC
1978

GRAND VIN
DE
CHATEAU LATOUR
PREMIER GRAND CRU CLASSE
PAUILLAC
1986



- 1936 Château Latour** (1)
Short capsule. Stained label. Level upper-shoulder
- 1937 Château Latour** (1)
Original short capsule. Danish slip label. Stained and slightly damaged label. Level mid-shoulder
- 1939 Château Latour** (1)
Recent capsule. Slightly depressed cork. Slight stained label. Level into neck
- 1940 Château Latour** (1)
Recent capsule. Slightly stained label. Level top-shoulder
- 1941 Château Latour** (1)
Reconditioned by Château in 1988. Level base of neck
- 1942 Château Latour** (1)
Corroded metal silver capsule. Stained label and slightly damaged label. Level mid-shoulder
- 1943 Château Latour** (1)
Original short capsule. Slightly stained label. Level mid-low shoulder
- 1944 Château Latour** (1)
Badly damaged original short capsule. Stained and slightly damaged label. Level top-shoulder
- 1945 Château Latour** (1)
Damaged original short capsule. Stained and badly damaged label. Level mid-upper shoulder
- 1946 Château Latour** (1)
Corroded original short capsule. Slightly stained label. Level mid-shoulder

- 1947 Château Latour** (1)
Corroded original short capsule. Badly stained and badly damaged label. Level mid-upper shoulder
- 1948 Château Latour** (1)
Corroded original short capsule. Stained and slightly damaged label. Level upper-shoulder
- 1949 Château Latour** (1)
Replacement "old style" capsule. Level top-shoulder
- 1950 Château Latour** (1)
Corroded original capsule. Slightly stained and slightly damaged label. Level upper-shoulder
- 1951 Château Latour** (1)
Slightly corroded original capsule. Danish slip label. Slightly stained label. Level upper-shoulder
- 1952 Château Latour** (1)
Slightly damaged original capsule. Slightly stained label. Level top-shoulder
- 1953 Château Latour** (1)
Original capsule. Danish slip label. Slightly stained label. Level mid-upper shoulder
- 1954 Château Latour** (1)
Slightly corroded original capsule. Stained label. Level upper-shoulder
- 1955 Château Latour** (1)
Original capsule. Slightly stained label. BBR shoulder label. Level upper-shoulder
- 1957 Château Latour** (1)
Original capsule. Slightly stained label. Level top-shoulder



Lot 6367

1958 Château Latour	(1)	1979 Château Latour	(1)
<i>Original capsule. Slightly protruding cork. Stained and creased label. Level base of neck</i>		<i>Danish slip label. Slightly damaged label. Level into neck</i>	
1959 Château Latour	(1)	1980 Château Latour	(1)
<i>Original capsule. Danish slip label. Slightly stained label. Level top-shoulder</i>		<i>Danish slip label. Level base of neck</i>	
1960 Château Latour	(1)	1981 Château Latour	(1)
<i>Corroded original capsule. Danish slip label. Stained and slightly creased label. Level low-shoulder</i>		<i>Danish slip label. Slightly stained label. Level base of neck</i>	
1961 Château Latour	(1)	1982 Château Latour	(1)
<i>Original capsule. Danish slip label. Slightly stained label. Level top-shoulder</i>		<i>Level base of neck</i>	
1962 Château Latour	(1)	1983 Château Latour	(1)
<i>Recent capsule. Danish slip label. Slightly stained. Level top-shoulder</i>		<i>Congée capsule. Level into neck</i>	
1963 Château Latour	(1)	1984 Château Latour	(1)
<i>Original capsule. Slightly stained and slightly damaged label. John Harvey and Sons Limited slip label. Level upper-shoulder</i>		<i>Danish slip label. Level into neck</i>	
1964 Château Latour	(1)	1985 Château Latour	(1)
<i>Original capsule. Danish slip label. Stained label. Level base of neck</i>		<i>Danish slip label. Level into neck</i>	
1965 Château Latour	(1)	1986 Château Latour	(1)
<i>Slightly stained label with Nicolas stamp. Level upper-shoulder</i>		<i>Slightly damaged capsule. Danish slip label. Level into neck</i>	
1966 Château Latour	(1)	1987 Château Latour	(1)
<i>Danish slip label. Badly stained label. Level mid-shoulder</i>		<i>Danish slip label. Level into neck</i>	
1967 Château Latour	(1)	1988 Château Latour	(1)
<i>Stained and slightly damaged label. Level top-shoulder</i>		<i>Very slightly damaged capsule. Slightly stained label. Level into neck</i>	
1968 Château Latour	(1)	1989 Château Latour	(1)
<i>Slightly stained and slightly damaged label. Level base of neck</i>		<i>Danish slip label. Level into neck</i>	
1969 Château Latour	(1)	1990 Château Latour	(1)
<i>Stained label. Level top-shoulder</i>		<i>Danish slip label. Slightly stained label Level base of neck</i>	
1970 Château Latour	(1)	1991 Château Latour	(1)
<i>Danish slip label. Slightly stained label. Level base of neck</i>		<i>Congée capsule. Level into neck</i>	
1971 Château Latour	(1)	1992 Château Latour	(1)
<i>Danish slip label. Slightly stained label. Level base of neck</i>		<i>Level base of neck</i>	
1972 Château Latour	(1)	1993 Château Latour	(1)
<i>Damaged capsule. Danish slip label. Stained and slightly damaged label. Level base of neck</i>		<i>Level into neck</i>	
1973 Château Latour	(1)	1994 Château Latour	(1)
<i>Slightly damaged capsule. Stained label. Level mid-upper shoulder</i>		<i>Level into neck</i>	
1974 Château Latour	(1)	1995 Château Latour	(1)
<i>Danish slip label. Stained and slightly damaged label. Level into neck</i>		<i>Danish slip label. Level into neck</i>	
1975 Château Latour	(1)	1996 Château Latour	(1)
<i>Slightly damaged capsule. Slightly depressed cork. Stained label. Level base of neck</i>		<i>Level into neck</i>	
1976 Château Latour	(1)	1997 Château Latour	(1)
<i>Danish slip label. Level base of neck</i>		<i>Level into neck</i>	
1977 Château Latour	(1)	1998 Château Latour	(1)
<i>Slightly depressed cork. Danish slip label. Very slightly damaged label. Level base of neck</i>		<i>Level into neck</i>	
1978 Château Latour	(1)	1999 Château Latour	(1)
<i>Slightly depressed cork. Level into neck</i>		<i>Level into neck</i>	
		2000 Château Latour	(1)
		<i>Congée capsule</i>	
		2001 Château Latour	(1)
		2002 Château Latour	(1)
		2003 Château Latour	(1)
		2004 Château Latour	(1)
		2005 Château Latour	(1)
		2006 Château Latour	(1)
		2007 Château Latour	(1)
		2008 Château Latour	(1)
	6367	Above 100 bottles	per lot HK\$800,000-1,500,000
		Offered in ten custom-made wooden presentation cases with an engraved metal plate listing the ten vintages of Château Latour enclosed within	

Château Mouton Rothschild - Premier Grand Cru Classé

Château Mouton Rothschild, a Premier Grand Cru Classé, now belongs to Camille Sereys de Rothschild, Philippe Sereys de Rothschild and Julien de Beaumarchais de Rothschild, the three children of Baroness Philippine de Rothschild and grandchildren of the legendary Baron Philippe. The estate comprises 83 hectares of vines in Pauillac, planted with Cabernet Sauvignon (81%), Merlot (15%), Cabernet Franc (3%) and Petit Verdot (1%), and boasts an exceptional terroir, both for the quality of its soil and its exposure to sunlight. Combining respect for tradition with the latest technology, meticulous care and attention are given from grape to bottle: hand picking, manual and optical sorting, fermentation vats with transparent staves and maturing in new oak barrels.

木桐 — 一等特級名莊

位列一等特級的木桐現由菲莉嬭·德·羅思柴爾德女男爵 (Baroness Philippine de Rothschild) 的三名子女及菲利普男爵 (Baron Philippe) 的孫兒持有 — 卡米爾·塞雷斯·德·羅思柴爾德 (Camille Sereys de Rothschild)、菲利普·塞雷斯·德·羅思柴爾德 (Philippe Sereys de Rothschild) 和朱利安·德·博馬舍·德·羅思柴爾德 (Julien de Beaumarchais de Rothschild)。酒莊擁有佔地 83 公頃的波亞克葡萄園，種植了赤霞珠 (81%)、美樂 (15%)、品麗珠 (3%) 和小味兒 (1%)，該處風土極佳，土壤優質，陽光充沛。從種植葡萄到裝瓶，每個細節均一絲不苟。遵從傳統的同時亦採用嶄新技術：以人手進行採摘及目測篩選，配備附透明側板的發酵桶，並以新橡木桶陳釀。

VERTICAL COLLECTIONS OF MOUTON ROTHSCHILD IN BOTTLES & MAGNUMS

The following two verticals of Château Mouton Rothschild are being sold by a private collector. The wines have been painstakingly amassed over a number of years from reputable sources. It is rare to see such vertical collections in such excellent condition, particularly with high fill levels, a testament to the vendor's fastidious collection and storage in ideal temperature and humidity controlled conditions in professional storage. The vertical collection of bottles is from 1945 through to 2005 and features two bottles of the 1978 & 1993 vintages with the two different labels that the Château released in those vintages. The vertical collection of magnums is from 1974 through to 2012 and also includes two magnums of the 1978 & 1993 vintages.

1978 & 1993 Vintages

The Canadian-born artist Jean-Paul Riopelle prepared two designs for the 1978 Mouton Rothschild label; it was impossible to choose between them and therefore both designs were used for half of the vintage each. The drawing that Balthus created for Mouton Rothschild 1993 featured a naked adolescent girl that was subsequently banned for the U.S. market and so another label was produced specifically for this market with the offending drawing removed.

木桐垂直系列 (標準瓶裝和 1.5 公升裝)

下列木桐垂直系列由一名私人藏家所售。此組窖藏經多年精心蒐集，而且來源可靠。如此優秀的垂直系列實屬少見，其高酒位更引證了藏家的嚴格挑選，每瓶皆貯存於具溫度和濕度調控的專業酒窖內。標準瓶裝垂直系列網羅 1945 年至 2005 年的美酒，當中包括兩瓶 1978 年和兩瓶 1993 年的年份珍釀，各附有酒莊在相關年份印製的兩款不同酒標。1.5 公升裝垂直系列則涵蓋 1974 年至 2012 年，同樣收藏兩瓶 1978 年和兩瓶 1993 年的年份佳釀。

1978 年與 1993 年

加拿大藝術家尚·保羅·里奧佩爾 (Jean-Paul Riopelle) 為 1978 年木桐設計了兩款酒標，由於難以取捨，故兩款設計被平均地採用於酒瓶之上，數量各佔一半。至於巴爾蒂斯 (Balthus) 繪畫的 1993 年木桐酒標，因帶有裸體少女肖像而被美國禁止推出，酒莊為此特別設計適用於美國市場的另一酒標，移除引起爭議的畫像。

Château Mouton Rothschild Vertical 1945-2005

- 1945 Château Mouton Rothschild** (1)
"Barton & Guestier, Bordeaux" slip label. Badly stained label. Level top-shoulder
- 1946 Château Mouton Rothschild** (1)
Stained label. Level top-shoulder
- 1947 Château Mouton Rothschild** (1)
Recorked in 1984. Very slightly stained label. Level base of neck
- 1948 Château Mouton Rothschild** (1)
Very slightly depressed cork. Very slightly stained label. Level top-shoulder
- 1949 Château Mouton Rothschild** (1)
Very slightly damaged capsule. Very slightly stained and slightly damaged label. Level very top-shoulder
- 1950 Château Mouton Rothschild** (1)
Corroded capsule. Stained and very slightly damaged label. Level upper-shoulder
- 1951 Château Mouton Rothschild** (1)
Slightly damaged capsule. Excellent label. Level upper-shoulder
- 1952 Château Mouton Rothschild** (1)
Excellent label. Level top-shoulder
- 1953 Château Mouton Rothschild** (1)
Slightly damaged capsule. Slightly stained label. Level top-shoulder
- 1954 Château Mouton Rothschild** (1)
Slightly damaged capsule. Slightly stained label. Level top-shoulder
- 1955 Château Mouton Rothschild** (1)
Level upper-shoulder
- 1956 Château Mouton Rothschild** (1)
Slightly stained label. Level top-shoulder
- 1957 Château Mouton Rothschild** (1)
Protruding cork and damaged capsule. Slightly stained label. Level top-shoulder
- 1958 Château Mouton Rothschild** (1)
Very slightly damaged capsule. Slightly stained and slightly damaged label. Level base of neck

1959 Château Mouton Rothschild	(1)	1970 Château Mouton Rothschild	(1)
<i>Slightly stained label. Level top-shoulder</i>		<i>Level upper-shoulder</i>	
1960 Château Mouton Rothschild	(1)	1971 Château Mouton Rothschild	(1)
<i>Very slightly damaged capsule. Slightly stained label. Level top-shoulder</i>		<i>Very slightly stained label. Level top-shoulder</i>	
1961 Château Mouton Rothschild	(1)	1972 Château Mouton Rothschild	(1)
<i>Very slightly stained and very slightly damaged label. Level top-shoulder</i>		<i>Level base of neck</i>	
1962 Château Mouton Rothschild	(1)	1973 Château Mouton Rothschild	(1)
<i>Stained label. Level top-shoulder</i>		<i>Very slightly damaged capsule. Very slightly stained label. Level top-shoulder</i>	
1963 Château Mouton Rothschild	(1)	1974 Château Mouton Rothschild	(1)
<i>Very slightly corroded capsule. Level upper-shoulder</i>		<i>Level top-shoulder</i>	
1964 Château Mouton Rothschild	(1)	1975 Château Mouton Rothschild	(1)
<i>Slightly damaged capsule. Slightly stained label. Level top-shoulder</i>		<i>Very slightly damaged capsule. Very slightly stained label. Level very top-shoulder</i>	
1965 Château Mouton Rothschild	(1)	1976 Château Mouton Rothschild	(1)
<i>Slightly stained label. Level into neck</i>		<i>Very slightly damaged capsule. Level top-shoulder</i>	
1966 Château Mouton Rothschild	(1)	1977 Château Mouton Rothschild	(1)
<i>Very slightly damaged capsule. Very slightly stained label. Level very top-shoulder</i>		<i>Very slightly damaged capsule. Level base of neck</i>	
1967 Château Mouton Rothschild	(1)	1978 Château Mouton Rothschild	(2)
<i>Very slightly corroded capsule. Stained label. Level top-shoulder</i>		<i>Very slightly damaged capsules. One very slightly stained label. Levels top-shoulder</i>	
1968 Château Mouton Rothschild	(1)	1979 Château Mouton Rothschild	(1)
<i>Very slightly corroded capsule. Stained label. Level top-shoulder</i>		<i>Very slightly damaged capsule. Level top-shoulder</i>	
1969 Château Mouton Rothschild	(1)	1980 Château Mouton Rothschild	(1)
<i>Very slightly damaged capsule. Very slightly stained label. Level top-shoulder</i>		<i>Very slightly stained label. Level base of neck</i>	
		1981 Château Mouton Rothschild	(1)
		<i>Very slightly stained label. Level base of neck</i>	
		1982 Château Mouton Rothschild	(1)
		<i>Very slightly damaged capsule. Very slightly stained label. Level base of neck</i>	



Lot 6368



CHATEAU MOUTON ROTHSCHILD

1986

la récolte 1986 se présente
291 500 bouteilles et est
7 250 magnifiques et splendides
tout en bouteilles au Château
avec 64 vendanges

Château
Mouton Rothschild
PAUILLAC

Baron Philippe de Rothschild

CHATEAU MOUTON ROTHSCHILD

1987

1987

Au nom du
Baron Philippe de Rothschild, résident au Château
je mets en bouteille ce vin de 68 ans
et dernière vendange

Château
Mouton Rothschild
PAUILLAC

Baron Philippe de Rothschild

CHATEAU MOUTON ROTHSCHILD

1989

Château
Mouton Rothschild
PAUILLAC

Baron Philippe de Rothschild

CHATEAU MOUTON ROTHSCHILD

1988

Château
Mouton Rothschild
PAUILLAC

Baron Philippe de Rothschild

CHATEAU MOUTON ROTHSCHILD

1990

Château
Mouton Rothschild
PAUILLAC

Baron Philippe de Rothschild

CHATEAU MOUTON ROTHSCHILD

1991

Château
Mouton Rothschild
PAUILLAC

Baron Philippe de Rothschild





Lot 6368

- | | | | |
|--|-----|---|-------------------------------|
| 1983 Château Mouton Rothschild | (1) | 1994 Château Mouton Rothschild | (1) |
| <i>Integrated US import front label. Level base of neck</i> | | <i>Excellent appearance. Level into neck</i> | |
| 1984 Château Mouton Rothschild | (1) | 1995 Château Mouton Rothschild | (1) |
| <i>Integrated US import front label. Level base of neck</i> | | <i>Excellent appearance. Level into neck</i> | |
| 1985 Château Mouton Rothschild | (1) | 1996 Château Mouton Rothschild | (1) |
| <i>Level top-shoulder</i> | | <i>Excellent appearance. Level into neck</i> | |
| 1986 Château Mouton Rothschild | (1) | 1997 Château Mouton Rothschild | (1) |
| <i>US import back label. Excellent appearance. Level into neck</i> | | <i>Excellent appearance. Level into neck</i> | |
| 1987 Château Mouton Rothschild | (1) | 1998 Château Mouton Rothschild | (1) |
| <i>Very slightly damaged integrated US import front label. Level base of neck</i> | | <i>Excellent appearance. Level into neck</i> | |
| 1988 Château Mouton Rothschild | (1) | 1999 Château Mouton Rothschild | (1) |
| <i>Excellent appearance. Level into neck</i> | | <i>Excellent appearance. Level into neck</i> | |
| 1989 Château Mouton Rothschild | (1) | 2000 Château Mouton Rothschild | (1) |
| <i>Excellent appearance. Level base of neck</i> | | <i>US import slip label. Level into neck</i> | |
| 1990 Château Mouton Rothschild | (1) | 2001 Château Mouton Rothschild | (1) |
| <i>Excellent appearance. Level base of neck</i> | | <i>Excellent appearance. Level into neck</i> | |
| 1991 Château Mouton Rothschild | (1) | 2002 Château Mouton Rothschild | (1) |
| <i>Excellent appearance. Level into neck</i> | | <i>Excellent appearance. Level into neck</i> | |
| 1992 Château Mouton Rothschild | (1) | 2003 Château Mouton Rothschild | (1) |
| <i>Very slightly stained label. Level into neck</i> | | <i>Stained label. Level into neck</i> | |
| 1993 Château Mouton Rothschild | (2) | 2004 Château Mouton Rothschild | (1) |
| <i>One Balthus label and one US market label with US import back label. Excellent appearance. Levels into neck</i> | | <i>Very slightly damaged label. Level into neck</i> | |
| | | 2005 Château Mouton Rothschild | (1) |
| | | <i>US import back label. Level into neck</i> | |
| | | 6368 Above 63 bottles | per lot HK\$600,000-1,200,000 |

**Château Mouton Rothschild Vertical in Magnum
1974 - 2012**

- 1974 Château Mouton Rothschild** magnum (1)
Very slightly damaged capsule. Slightly stained label. Level top-shoulder
- 1975 Château Mouton Rothschild** magnum (1)
Very slightly stained label. Level base of neck
- 1976 Château Mouton Rothschild** magnum (1)
Very slightly damaged capsule. Level base of neck
- 1977 Château Mouton Rothschild** magnum (1)
Very slightly damaged capsule. Very slightly stained label. Level base of neck
- 1978 Château Mouton Rothschild** magnums (2)
One very slightly damaged capsule. One very slightly stained label. Levels base of neck
- 1979 Château Mouton Rothschild** magnum (1)
Very slightly damaged capsule. Stained and slightly damaged label. Level base of neck
- 1980 Château Mouton Rothschild** magnum (1)
Level top-shoulder
- 1981 Château Mouton Rothschild** magnum (1)
Very slightly stained label. Level base of neck
- 1982 Château Mouton Rothschild** magnum (1)
Very slightly stained and slightly damaged label. Level base of neck
- 1983 Château Mouton Rothschild** magnum (1)
Stained and very slightly damaged label. Level into neck
- 1984 Château Mouton Rothschild** magnum (1)
Very slightly stained label. Level into neck
- 1985 Château Mouton Rothschild** magnum (1)
Very slightly stained label. Level base of neck

- 1986 Château Mouton Rothschild** magnum (1)
Excellent appearance. Level base of neck
- 1987 Château Mouton Rothschild** magnum (1)
Excellent appearance. Level into neck
- 1988 Château Mouton Rothschild** magnum (1)
Excellent appearance. Level into neck
- 1989 Château Mouton Rothschild** magnum (1)
Excellent appearance. Level into neck
- 1990 Château Mouton Rothschild** magnum (1)
In single-magnum wooden case. Excellent appearance. Level into neck
- 1991 Château Mouton Rothschild** magnum (1)
Excellent appearance. Level into neck
- 1992 Château Mouton Rothschild** magnum (1)
Excellent appearance. Level into neck
- 1993 Château Mouton Rothschild** magnums (2)
One Balthus label. Level into neck. One in single-magnum original wooden case with US market label. Excellent appearance. Level into neck
- 1994 Château Mouton Rothschild** magnum (1)
Very slightly damaged capsule. Very slightly stained label. Level into neck
- 1995 Château Mouton Rothschild** magnum (1)
Excellent appearance. Level into neck
- 1996 Château Mouton Rothschild** magnum (1)
Excellent appearance. Level into neck
- 1997 Château Mouton Rothschild** magnum (1)
Very slightly depressed cork. Level into neck
- 1998 Château Mouton Rothschild** magnum (1)
Excellent appearance. Level into neck
- 1999 Château Mouton Rothschild** magnum (1)
Excellent appearance. Level into neck



Lot 6369

	2000 Château Mouton Rothschild	magnum (1)	
	<i>Excellent appearance. Level into neck</i>		
	2001 Château Mouton Rothschild	magnum (1)	
	<i>Excellent appearance. Level into neck</i>		
	2002 Château Mouton Rothschild	magnum (1)	
	<i>Excellent appearance. Level into neck</i>		
	2003 Château Mouton Rothschild	magnum (1)	
	<i>Excellent appearance. Level into neck</i>		
	2004 Château Mouton Rothschild	magnum (1)	
	<i>Excellent appearance. Level into neck</i>		
	2005 Château Mouton Rothschild	magnum (1)	
	<i>In single-magnum original wooden case. Excellent appearance. Level into neck</i>		
	2006 Château Mouton Rothschild	magnum (1)	
	<i>In single-magnum original wooden case. Excellent appearance. Level into neck</i>		
	2007 Château Mouton Rothschild	magnum (1)	
	<i>In single-magnum original wooden case. Excellent appearance. Level into neck</i>		
	2008 Château Mouton Rothschild	magnum (1)	
	<i>In single-magnum original wooden case. Excellent appearance. Level into neck</i>		
	2009 Château Mouton Rothschild	magnum (1)	
	<i>In single-magnum original wooden case. Excellent appearance. Level into neck</i>		
	2010 Château Mouton Rothschild	magnum (1)	
	<i>In single-magnum original wooden case. Excellent appearance. Level into neck</i>		
	2011 Château Mouton Rothschild	magnum (1)	
	<i>In single-magnum original wooden case. Excellent appearance. Level into neck</i>		
	2012 Château Mouton Rothschild	magnum (1)	
	<i>Excellent appearance. Level into neck</i>		
6369	Above 41 magnums		per lot HK\$500,000-1,000,000

FINE VINTAGES OF BORDEAUX, BURGUNDY, RHONE & ITALY FROM A PRIVATE COLLECTOR

Mixed Château Cos d'Estournel

	1985 Château Cos d'Estournel	(2)	
	<i>Slightly damaged labels. Levels base of neck</i>		
	1988 Château Cos d'Estournel	(3)	
	<i>Japanese import slip labels. Levels into neck</i>		
	1989 Château Cos d'Estournel	(5)	
	<i>Japanese import slip labels. Levels three into neck and two base of neck</i>		
6370	Above 10 bottles		per lot HK\$10,000-15,000

Château Cos d'Estournel 2007

	<i>Saint-Estéphe, 2ème cru classé</i>		
	<i>In original wooden case. Japanese import slip labels</i>		
6371	12 bottles		per lot HK\$7,000-10,000

Château Cos d'Estournel 2009

	<i>Saint-Estéphe, 2ème cru classé</i>		
	<i>In six-bottle original wooden cases. Japanese import slip labels</i>		
6372	12 bottles		per lot HK\$22,000-35,000

Mixed Cos d'Estournel

	2010 Château Cos d'Estournel	(6)	
	2011 Château Cos d'Estournel	(6)	
	2012 Château Cos d'Estournel	(6)	
	<i>All in six-bottle original wooden cases. Japanese import slip labels</i>		
6373	Above 18 bottles		per lot HK\$16,000-24,000

Château Latour 1982

	<i>Pauillac, 1er cru classé</i>		
	<i>Japanese import neck label. Slightly creased label. Level base of neck</i>		
6374	1 bottle		per lot HK\$12,000-18,000

Château Latour 1990

	<i>Pauillac, 1er cru classé</i>		
	<i>Three slightly damaged capsules. Japanese import slip labels. Levels base of neck or better</i>		
6375	4 bottles		per lot HK\$20,000-30,000

Mixed Bordeaux Grand Cru Classé

	1988 Château Léoville-Las-Cases	(1)	
	<i>Corroded capsule. Slightly damaged label. Japanese import slip label. Level base of neck</i>		
	1993 Château Léoville-Las-Cases	(1)	
	<i>Very slightly stained label. Japanese import slip label. Level into neck</i>		
	1982 Château Montrose	(1)	
	<i>Damaged capsule. Stained label. Level top-shoulder</i>		
6376	Above 3 bottles		per lot HK\$3,500-5,000

Mixed Ausone and Cheval-Blanc

	1992 Château Ausone	(1)	
	<i>Japanese import slip label. Slightly stained label. Level base of neck</i>		
	1993 Château Ausone	(1)	
	<i>Japanese import slip label. Slightly stained label. Level into neck</i>		
	1970 Château Cheval-Blanc	(1)	
	<i>Slightly damaged capsule. Stained label. Japanese import slip label. Level top-shoulder</i>		
6377	Above 3 bottles		per lot HK\$8,000-11,000

Petrus 1982*Pomerol, cru exceptionnel**Very slightly damaged capsule. Stained and slightly damaged label. US import slip label. Level into neck.*6378 1 bottle *per lot* HK\$28,000-42,000**Domaine des Comtes Lafon, Meursult-Charmes 1999***Côte de Beaune. Comtes Lafon**Levels 1.5cms or better*6379 7 bottles *per lot* HK\$12,000-17,000**Domaine G. Roumier, Bonnes-Mares 2003***Grand Cru, Côte de Nuits**In original carton*6380 6 bottles *per lot* HK\$28,000-42,000**Domaine G. Roumier, Bonnes-Mares 2004***Grand Cru, Côte de Nuits**In twelve-bottle original carton*6381 7 bottles *per lot* HK\$40,000-60,000**Domaine G. Roumier, Morey-Saint-Denis Clos de la Bussière 2009***Côte de Nuits**Japanese import slip labels*6382 5 bottles *per lot* HK\$3,800-6,000**Domaine de la Romanée-Conti, Romanée-Conti 2001***Grand Cru, Côte de Nuits**Wilson Daniels back label. Japanese import slip label.**Very slightly stained label*6383 1 bottle *per lot* HK\$80,000-120,000**Domaine de la Romanée-Conti, La Tâche 1986***Grand Cru, Côte de Nuits**Very slightly protruding cork. Leroy slip label. Japanese import label. Level 3cms*6384 1 bottle *per lot* HK\$16,000-24,000**Domaine de la Romanée-Conti, Romanée-Saint-Vivant 1988***Grand Cru, Côte de Nuits**Wilson Daniels slip label. Japanese import slip label.**Slightly stained label. Level 2cms*6385 1 bottle *per lot* HK\$7,500-11,000**Domaine de la Romanée-Conti, Grands-Echézeaux 1972***Grand Cru, Côte de Nuits**Badly stained and damaged label. Japanese import slip label. Level 3cms*6386 1 bottle *per lot* HK\$7,000-10,000**Henri Jayer, Echézeaux 1976***Grand Cru, Côte de Nuits**Very slightly damaged capsule. Slightly stained and damaged label. Level 2.5cms*6387 1 bottle *per lot* HK\$38,000-55,000**Georges et Henri Jayer, Echézeaux 1985***Grand Cru, Côte de Nuits**Slightly damaged capsule. Damaged label. Level 1.5cms*6388 1 bottle *per lot* HK\$28,000-42,000

Lots 6380-6382

Henri Jay, Vosne-Romanée Cros-Parantoux 1996

*1er Cru, Côte de Nuits
Two slightly depressed corks. Slightly stained labels.
Levels 1cm or better*

6389 5 bottles *per lot* HK\$280,000-420,000

Jacques-Frédéric Mugnier, Musigny 1990

*Grand Cru, Côte de Nuits
Very slightly stained and damaged labels. Levels 1cm*

6390 2 bottles *per lot* HK\$24,000-35,000

Jacques-Frédéric Mugnier, Musigny 2000

*Grand Cru, Côte de Nuits
One very slightly damaged vintage neck label.
Japanese import slip labels. Levels 1.5cms or better*

6391 4 bottles *per lot* HK\$22,000-32,000

Jacques-Frédéric Mugnier, Musigny 2002

*Grand Cru, Côte de Nuits
One very slightly damaged label. Japanese import slip labels*

6392 2 bottles *per lot* HK\$18,000-26,000

Jacques-Frédéric Mugnier, Musigny 2005

*Grand Cru, Côte de Nuits
In original wooden case. Levels 1cm*

6393 6 bottles *per lot* HK\$110,000-160,000

Jacques-Frédéric Mugnier, Chambolle-Musigny 2009

*Côte de Nuits
In six-bottle original wooden cases, one without lid.
Japanese import slip labels*

6394 12 bottles *per lot* HK\$8,500-13,000

Jacques-Frédéric Mugnier, Chambolle-Musigny 2010

*Côte de Nuits
In original wooden case. Japanese import slip labels*

6395 6 bottles *per lot* HK\$5,000-8,000

Mommessin, Clos de Tart 1999

*Grand Cru, Côte de Nuits
Very slightly damaged vintage neck labels. One stained and one very slightly damaged labels.
Japanese import slip labels*

6396 4 bottles *per lot* HK\$10,000-15,000

Mixed Burgundy

1983 Domaine Michel Voarick, Romanée Saint-Vivant (1)

Very slightly damaged capsule. Slightly depressed cork. Creased vintage neck label. Stained and damaged label. Level 2cms

2000 Mommessin, Clos de Tart (1)

Very slightly damaged capsule. Japanese import slip label

2001 Maison Leroy, Bourgogne Aligote (1)

*Very slightly damaged capsule. Very slightly damaged vintage neck label. Very slightly stained label.
Japanese import slip label*

6397 Above 3 bottles *per lot* HK\$3,500-5,500

Mixed Guigal

1994 E. Guigal, Côte-Rôtie La Mouline (1)

Slightly damaged label. Level 0.5cm

1994 E. Guigal, Côte-Rôtie La Turque (1)

Slightly depressed cork. Slightly stained and very slightly damaged label. Level 0.5cm

6398 Above 2 bottles *per lot* HK\$4,200-6,000



Lots 6390-6393

Mixed Italian**1987 Case Basse di Gianfranco Soldera, Bruello di Montalcino** (2)*One very slightly damaged label. Japanese import slip labels. Levels into neck***1997 Gaja, Sori San Lorenzo** (1)*Slightly damaged label. Level 1cm***1997 Gaja, Sori Tildin** (1)*Slightly damaged label. Level 1cm*6399 Above 4 bottles *per lot* HK\$11,000-17,000**Mixed Ornellaia and Masseto****1999 Tenuta Dell'Ornellaia, Ornellaia** (2)*Japanese import slip labels***2000 Tenuta Dell'Ornellaia, Masseto** (1)6400 Above 3 bottles *per lot* HK\$6,000-9,000**LA TACHE 1991 & 1993 FROM A PRIVATE COLLECTOR****Domaine de la Romanée-Conti La Tâche 1991***Grand Cru, Côte de Nuits**Stained and slightly damaged vintage neck labels.**Stained labels, one slightly damaged. Damaged HK**import back labels. Levels one 1.5cms and one 2.5cms*6401 2 bottles *per lot* HK\$30,000-50,000**Domaine de la Romanée-Conti La Tâche 1993***Grand Cru, Côte de Nuits**In original wooden case. Damaged wax capsule with**sign of old seepage. Wilson Daniels import back label.**Excellent appearance. Level 4cms*6402 1 jeroboam *per lot* HK\$80,000-120,000**Domaine de la Romanée-Conti La Tâche 1993***Grand Cru, Côte de Nuits**In original wooden case. Slightly damaged wax**capsule with sign of old seepage. Wilson Daniels**import back label. Very slightly damaged label**otherwise good appearance. Level 5cms*6403 1 methuselah *per lot* HK\$160,000-240,000**SUPERLATIVE WINES INCLUDING FROM THE LEGENDARY HENRI JAYER FROM A PRIVATE COLLECTOR****Henri Jaye, Echézeaux 1980***Grand Cru, Côte de Nuits**Very slightly damaged capsule. Badly damaged label.**Level 3cms*6404 1 bottle *per lot* HK\$24,000-38,000**Henri Jaye, Echézeaux 1984***Grand Cru, Côte de Nuits**Very slightly stained labels, one slightly damaged and**wrinkled. Levels 2.2cms*6405 2 bottles *per lot* HK\$28,000-48,000**Henri Jaye, Echézeaux 1985***Grand Cru, Côte de Nuits**Very slightly stained label. Level 1cm*6406 1 bottle *per lot* HK\$20,000-40,000**Henri Jaye, Echézeaux 1986***Grand Cru, Côte de Nuits**Slightly damaged capsules. Slightly depressed corks.**Slightly stained vintage neck labels. Badly stained and**slightly damaged labels. Levels 2cms*6407 2 bottles *per lot* HK\$48,000-75,000**Henri Jaye, Echézeaux 1987***Grand Cru, Côte de Nuits**Slightly stained label. Level 3.5cms*6408 1 bottle *per lot* HK\$15,000-20,000**Henri Jaye, Nuits-Saint-Georges Murgers 1986***1er Cru, Côte de Nuits**Very slightly damaged capsule. Stained vintage neck**label and label. Level 2.5cms*6409 1 bottle *per lot* HK\$18,000-30,000**Henri Jaye, Vosne-Romanée Cros-Parantoux 1980***1er Cru, Côte de Nuits**Damaged label. "Macon Medaille d'Or" slip label. Level**4.3cms*6410 1 bottle *per lot* HK\$24,000-38,000

Henri Jaye, Vosne-Romanée Cros-Parantoux 1981

*1er Cru, Côte de Nuits
Australian import back label. Badly damaged, remains
of label. Level 3cms*

6411 1 bottle *per lot* HK\$16,000-28,000

Henri Jaye, Vosne-Romanée Cros-Parantoux 1984

*1er Cru, Côte de Nuits
One slightly damaged and one badly damaged,
remains of label. Levels one 2.8cms and one 3.8cms*

6412 2 bottles *per lot* HK\$40,000-70,000

Henri Jaye, Vosne-Romanée Cros-Parantoux 1986

*1er Cru, Côte de Nuits
Slightly damaged vintage neck label. Slightly stained
label. Level 2cms*

6413 1 bottle *per lot* HK\$32,000-48,000

Henri Jaye, Vosne-Romanée Les Brulées 1986

*1er Cru, Côte de Nuits
One slightly damaged capsule. One slightly depressed
cork. One very slightly damaged vintage neck label.
Stained labels. Levels one 3.5cms and one 3.8cms*

6414 2 bottles *per lot* HK\$22,000-40,000

Henri Jaye, Vosne-Romanée Les Beaux Monts 1986

*1er Cru, Côte de Nuits
One slightly damaged capsule. Damaged and slightly
stained labels. Levels one 2cms and one 2.5cms*

6415 2 bottles *per lot* HK\$40,000-70,000

Mixed 1982 J.F.Coche-Dury

1982 Meursault (2)
*One slightly wrinkled label. Mature colour. Levels one
2.2cms and one 4.2cms*

1982 Meursault-Charmes (2)
*One slightly depressed cork. Very slightly damaged
vintage neck labels. Mature colour. Levels one 2.2cms
and one 2.5cms*

1982 Meursault Les Perrières (1)
*Very slightly damaged label. Mature colour. Level
2.7cms*

6416 *All Australian import back labels*
Above 5 bottles *per lot* HK\$35,000-65,000

Mixed Bordeaux

1982 Château Mouton Rothschild (1)

*Very slightly damaged capsule and label. Level top-
shoulder*

1989 Château Haut-Brion (1)

Level 1cm

6417 Above 2 bottles *per lot* HK\$14,000-22,000

**FINE WINES FROM BORDEAUX, RHONE,
BURGUNDY & GERMANY****Clos des Papes, Châteauneuf-du-Pape 1990**

Rhône

Good appearance. Levels 1cm or better

6418 12 bottles *per lot* HK\$15,000-22,000

Mixed French

1988 Roty, Marsannay (11)

*In original carton. Slightly stained labels. Levels
1.5cms or better*

1997 Domaine Brintet, Mercurey La Charmée (11)

1998 Cuvée de la Commanderie de Bontemps (12)

In original wooden case

2000 Château Tire Pe La Cote (12)

In original carton

2002 Denis Mortet, Bourgogne Blanc (8)

Slightly discolored capsules, two slightly damaged.

Slightly stained labels

**2010 Camus Bruchon, Savigny lès Beaune
Lavières** (6)

In original carton

**2011 Jean-Marc Vincent, Santenay Rouge
Gravières** (6)

In original carton

**2011 Cave de Turckheim Gewürztraminer Vieilles
Vignes** (24)

In original cartons

6419 Above 90 bottles *per lot* HK\$11,000-16,000

Mixed Rhône & Germany

**1998 Domaine des Sénéchaux, Châteauneuf-du-
Pape** (12)

In original carton

2008 Château Mont-Redon, Lirac (12)

2009 Château Mont-Redon, Lirac (12)

In original carton

**2008 Schmitges Erdener Prälät "Alte Reben"
Riesling Spätlese** (6)

In original carton. One slightly stained label

6420 Above 42 bottles *per lot* HK\$4,500-7,500

FINE WINES FROM FRANCE

Mixed 1980 Lancart l'Ainée

1980 Lancart l'Ainée, Aloxe-Corton (2)
Stained and damaged labels. Levels one 2cms and one 2.5cms

1980 Lancart l'Ainée, Pommard (20)
Some very slightly damaged capsules with signs of old seepage. Stained and damaged labels and vintage neck labels. Levels twelve 2.5cms, four 3cms, one 3.5cms, one 4cms, one 4.5cms and one 5.5cms

1980 Lancart l'Ainée, Vosne-Romanée (13)
Some very slightly damaged capsules with slight sign of old seepage. Slightly stained and damaged labels and neck labels. Levels seven 2.5cms, four 3cms, one 3.5cms and one 4.5cms

1980 Lancart l'Ainée, Gevrey-Chambertin (4)
Slightly damaged capsules. Slightly stained and damaged labels. Levels three 2.5cms and one 3.5cms

1980 Lancart l'Ainée, Volnay (8)
Some very slightly damaged capsules. Slightly stained and damaged labels. Levels six 2.5cms or better, one 3.5cms and one 4cms

1981 Lancart l'Ainée, Vosne-Romanée (8)
Some very slightly damaged capsules. Slightly stained and damaged labels. Levels 2cms or better

1981 Lancart l'Ainée, Gevrey-Chambertin (15)
Some slightly damaged capsules. Stained and slightly damaged labels. Levels 2.5cms or better

1982 Lancart l'Ainée, Pommard (5)
One damaged capsule. Stained labels, some slightly damaged. Levels 2cms or better

1982 Lancart l'Ainée, Chambolle-Musigny (1)
Stained and damaged label. Level 2cms

1982 Lancart l'Ainée, Aloxe-Corton (2)
Stained and damaged labels. Levels 2cms or better

1982 Lancart l'Ainée, Nuits-Saint-Georges (12)
Some very slightly damaged capsules with slight sign of old seepage. Stained and slightly damaged labels and neck labels. Levels ten 2cms or better and two 2.5cms

1985 Lancart l'Ainée, Beaune 1er Cru Les Grèves (6)
Damaged capsules with sign of seepage. Stained and damaged labels and vintage neck labels. Levels two 3cms and four 4cms

1985 Lancart l'Ainée, Corton Renardes (4)
Slightly damaged capsules with signs of seepage. Stained and damaged labels and vintage neck labels. Levels two 2.5cms and two 3cms

1985 Lancart l'Ainée, Rully (2)
Damaged and badly stained labels. Levels one 1.5cms and one 3cms

6421 Above 102 bottles per lot HK\$12,000-20,000

Château Lafite-Rothschild 1961

*Paulliac, 1er cru classé
 Slightly damaged short Château-embossed capsules.
 One badly depressed cork. Very slightly stained labels.
 Japanese import back labels. Levels top-shoulder*

6422 2 magnums per lot HK\$20,000-40,000

Mixed M. Chapoutier Ermitage

1995 M. Chapoutier, Hermitage L'Orée (5)
One very slightly damaged label. US slip labels. Levels 1cm

1998 M. Chapoutier, Ermitage Le Meal Blanc (6)
In original wooden case

2001 M. Chapoutier, Ermitage Le Meal (5)
Three very slightly damaged labels. Integrated US import back labels

6423 Above 16 bottles per lot HK\$13,000-18,000



Decanter
 ASIA WINE AWARDS
 2016

Mixed Lots from the 2016 Decanter Asia Wine Awards

The following lots 6424 to 6478 are offered on behalf of Decanter and are drawn from the samples submitted to their 2016 Asia Wine Awards. A significant portion of the funds raised from the sale will go to The Decanter Asia Wine Scholarship Programme, which supports Asia's most promising wine palates and future wine professionals. The scholarship programme gives tomorrow's experts the opportunity to study the vineyards of the world and to become world opinion formers in the industry. This programme will help create the upcoming leaders of the Asian wine industry.

Each case contains 12 different bottles from the region or country indicated and all are packed in cartons following selection by the Christie's and Decanter teams.

Lots 6424 to 6478 are offered with no reserves

Champagne

From the pre-eminent sparkling wine region in the world, these cases feature Vintage and Non-Vintage, white and rosé Champagnes.

•6424 24 bottles per lot HK\$5,500-8,000
 •6425 24 "
 •6426 24 "
 •6427 30 bottles per lot HK\$6,000-9,000

Bordeaux

Mixed cases of red wines - and perhaps the occasional white - from the most famous wine region in the world. Wines from prestigious Left-Bank and Right-Bank villages are to be found amongst these cases.

- 6428 12 bottles per lot HK\$1,200-1,800
- 6429 24 bottles per lot HK\$2,400-3,500
- 6430 60 bottles per lot HK\$6,000-9,000
- 6431 60 "
- 6432 60 "

Rhône

Cases of largely red wines, representing some of Rhône's classic regions including Côtes du Rhône and Châteauneuf-du-Pape.

- 6433 36 bottles per lot HK\$3,000-5,000
- 6434 36 "
- 6435 36 "

Tuscany

Some of Tuscany's most famous names including Chianti, Chianti Classico and Brunello di Montalcino.

- 6436 24 bottles per lot HK\$1,500-2,000
- 6437 24 "
- 6438 84 bottles per lot HK\$5,000-7,000
- 6439 84 "
- 6440 84 "
- 6441 84 "

Piedmont

Arguably Italy's most revered wine region, these cases of Piedmont wines offer wonderful examples of Barolo and Barbera d'Asti amongst others.

- 6442 84 bottles per lot HK\$5,500-8,000
- 6443 84 "
- 6444 84 "

Spain

Showcasing Spain's diversity, these cases include examples that hail from the length and breadth of the country; regions being represented including Cava, Ribera del Duero, Priorat, Toro, Rías Baixas and, of course, Rioja.

- 6445 60 bottles per lot HK\$4,000-7,000
- 6446 60 "
- 6447 60 "
- 6448 96 bottles per lot HK\$6,500-11,000
- 6449 96 "
- 6450 96 "
- 6451 108 bottles per lot HK\$7,500-13,000
- 6452 108 "

Veneto

The land of Valpolicella, Amarone, and Prosecco, these cases will show you the diversity and quality found in North-East Italy.

- 6453 84 bottles per lot HK\$5,500-7,500
- 6454 84 "
- 6455 84 "
- 6456 96 bottles per lot HK\$6,500-9,000

Australia

A varied assortment of wines from throughout Australia, including classic styles from Victoria, Western Australia and South Australia.

- 6457 120 bottles per lot HK\$8,000-10,000
- 6458 120 "
- 6459 120 "
- 6460 120 "
- 6461 120 "
- 6462 120 "
- 6463 120 "
- 6464 120 "
- 6465 192 bottles per lot HK\$13,000-16,000
- 6466 192 "

New Zealand

The 'Land of the Long White Cloud' produces some of the very best examples of New World Pinot Noir and Sauvignon Blanc. Sample these and more in these cases which demonstrate New Zealand's stunning quality.

- 6467 84 bottles per lot HK\$5,500-8,500
- 6468 84 "
- 6469 84 "
- 6470 84 "
- 6471 84 "

North America

Cases of Californian wines, containing offerings made from the grape that made the region famous - Cabernet Sauvignon - as well as Chardonnay, Merlot and Pinot Noir, and a selection of wines from Canada, including Ice Wine.

- 6472 60 bottles per lot HK\$4,000-6,000
- 6473 72 bottles per lot HK\$4,800-7,000
- 6474 72 "

Gold and Regional Trophies

A selection of the very best offerings from all four corners of the globe; these are all wines which were given the gold standard by expert judges.

•6475	24 bottles	per lot	HK\$2,800-4,000
•6476	24 "		
•6477	24 "		
•6478	24 "		

SASSICAIA FROM THE SUPERB 2006 VINTAGE

Sassicaia 2006

Tuscany

In six-bottle original wooden cases

6479	6 bottles	per lot	HK\$7,500-11,000
6480	6 "		

OUTSTANDING 1966 LA TACHE AND 1993 CLOS SAINT JACQUES FROM ROUSSEAU

Domaine de la Romanée-Conti, La Tâche 1966

Grand Cru, Côte de Nuits

One sign of old seepage. Frederick Wildman slip labels. US slip labels. Good appearance. Levels one 3.7cms, one 4.3cms, one 4.7cms, two 5cms and one 5.5cms

6481	6 bottles	per lot	HK\$80,000-130,000
------	-----------	---------	--------------------

Armand Rousseau, Gevrey-Chambertin Clos Saint Jacques 1993

1er Cru, Côte de Nuits

Signs of old seepage. Six wine-stained vintage neck labels, one slightly detached. Three wine-stained and one slightly damaged labels. US slip labels. Levels 1.5cms or better

6482	8 bottles	per lot	HK\$45,000-65,000
------	-----------	---------	-------------------

2009 & 2010 BORDEAUX FROM A PRIVATE COLLECTOR

Château Grand-Puy-Lacoste 2010

Pauillac, 5ème cru classé

In six-bottle original wooden cases

6483	12 bottles	per lot	HK\$4,500-7,000
------	------------	---------	-----------------

Château Ausone 2009

Saint-Emilion, 1er grand cru classé

In banded original wooden cases

6484	1 impérial	per lot	HK\$35,000-60,000
6485	1 "		

LEGENDARY 1990 VINTAGE OF BEAUSEJOUR-DUFFAU-LAGARROSSE & BARSAC DIRECT FROM OCTAVIAN VAULTS

Château Beauséjour-Duffau-Lagarrosse 1990

Saint-Emilion, 1er grand cru classé

In six-bottle original wooden cases. Badly stained and slightly damaged labels. Levels base of neck

6486	12 bottles	per lot	HK\$40,000-60,000
------	------------	---------	-------------------

Mixed Barsac

1988 Château Climens

impérials (2)

In original wooden cases, one damaged. One badly stained and damaged label, one slightly stained label. Levels into neck

1989 Château Climens

half-bottles (12)

In twenty-four half-bottle original wooden case with damaged lid. Excellent appearance. Levels into neck

1988 Château Coutet

impérial (1)

In damaged original wooden case. Slight sign of old seepage. Stained and slightly damaged label. Level into neck

1989 Château Coutet

half-bottles (12)

Lichine capsules. Glue-marked and stained labels. Levels base of neck

6487	Above 3 impérials and 24 half-bottles	per lot	HK\$10,000-15,000
------	---------------------------------------	---------	-------------------

CHAMPAGNE, BORDEAUX & BURGUNDY

Louis Roederer, Cristal 1999

Reims

In six-bottle original cartons

▲6488	12 bottles	per lot	HK\$26,000-38,000
-------	------------	---------	-------------------

Château Lafite-Rothschild 1961

Pauillac, 1er cru classé

Excellent appearance. Level just below top-shoulder

▲6489	1 double-magnum	per lot	HK\$22,000-32,000
-------	-----------------	---------	-------------------

Château Palmer 1945

*Cantenac (Margaux), 3me cru classé
Slightly corroded capsule. Bin-soiled and slightly
damaged label. Level mid-shoulder*

△6490 1 bottle per lot HK\$9,500-15,000

Lot 6490

脆皮乳鴿配 Chateau Palmer

脆皮乳鴿屬於粵菜，選用飼養 30 天左右的肉鴿製作，因此肉質入口鮮嫩，是上佳的滋補品。脆皮乳鴿有三種做法，可以生炸、熟炸和烤炸。生炸有投機取巧的嫌疑，熟炸則是更常見的做法。熟炸法的關鍵步驟就是在炸之前先用鹵水將乳鴿煮熟，所用的鹵水以高湯和香料配成，能夠讓乳鴿更加入味。同時，這一煮熟的過程也保證乳鴿的肉質更加鮮嫩，避免油炸而失水過度帶來的不良口感。烤炸法類似燜爐烤鴨的製作過程，在油炸前將乳鴿在燜爐中小火燜烤，同樣可以確保肉質的鮮嫩。脆皮乳鴿野味十足，肉質鮮嫩，可以選用波爾多瑪歌地區的 Chateau Palmer，丹甯細膩而絲滑，可以很好的搭配焦蘇的脆皮，乳鴿本身的野味也很適合赤霞珠葡萄的黑色水果和香料氣息。

張脩翰，丙申年初

Château Cheval-Blanc 1900

*Saint-Emilion, 1er grand cru classé (A)
Re-corked at the Château, date unknown. Remains
of top of capsule only. Fully branded cork. Original
label, badly bin-soiled and faded. Level top-shoulder.
Good colour. Bottle has small blister in glass at base
of shoulder*

△6491 1 magnum per lot HK\$65,000-95,000

Mixed Domaine Faiveley, Chambertin-Clos-de-Bèze

2010 Domaine Faiveley, Chambertin-Clos-de-Bèze (6)

2011 Domaine Faiveley, Chambertin-Clos-de-Bèze Ouvrées Rodin (6)

In original wooden cases

△6492 Above 12 bottles per lot HK\$32,000-48,000

Saint-Émilion 2003

*Saint-Emilion. Third wine of Château Cheval-Blanc
Very slightly stained labels*

△6493 10 bottles per lot HK\$2,600-3,800

Etienne Sauzet, Montrachet 2010

*Grand Cru, Côte de Beaune
In original wooden case*

△6494 1 jeroam per lot HK\$14,000-24,000

End of Sale
拍賣結束



Index by Vintage

WINE	Lot No.	WINE	Lot No.
CHAMPAGNE			
1979		1891	
Krug Collection	6002	Château Latour	6355
1985		1900	
Dom Pérignon Rosé	6001	Château Cheval Blanc	6491
Veuve Clicquot Rosé	6008	1945	
1989		Château Palmer	6490
Cristal Rosé Brut Vintage	6007	1961	
1995		Château Canon	6027
Krug Clos du Mesnil	6003	Château Lafite-Rothschild	6422, 6489
Krug	6004	1970	
Louis Roederer Brut	6163	Château Latour	6009
1999		Château Lafleur	6023
Cristal Brut Vintage	6005	1975	
Louis Roederer, Cristal	6488	Château Haut-Brion	6015
2000		1978	
Cristal Rosé Brut Vintage	6006	Petrus	6018
		1982	
		Petrus	6019, 6275, 6378
		Château Canon	6028
		Château Cos d'Estournel	6114
		Château Lynch-Bages	6141
		Château Margaux	6142
		Château Latour	6374
		1988	
		Petrus	6020
		1990	
		Château Cheval Blanc	6026
		Château Lafleur	6080
		Château Margaux	6143
		Château Haut-Brion	6144-6146
		Château Latour	6375
		Château Beauséjour-Duffau-Lagarrosse	6486
		1994	
		Château Lafite-Rothschild	6115
		1995	
		Petrus	6021, 6075
		Le Pin	6078
		Château Latour	6149-6155
		Château Ducru-Beaucaillou	6156-6157
		Château du Tertre	6158
		Château Haut-Brion	6159
		Château La Mission-Haut-Brion	6160-6161
		Château Lafite-Rothschild	6169-6170
		1998	
		Petrus	6022, 6076
		Château Lafite-Rothschild	6116, 6171
		1999	
		Château Lafite-Rothschild	6117
BORDEAUX WHITE			
1957			
Château de Rayne-Vigneau	6031		
1989			
Château Haut-Brion Blanc	6029		
Château d'Yquem	6147-6148		
1993			
Château Haut-Brion Blanc	6030		
2003			
Château d'Yquem	6325-6331		
2004			
Château d'Yquem	6332-6337		
2005			
Château d'Yquem	6338-6339		
Château Doisy Daëne Extravagant	6343		
2006			
Château d'Yquem	6340-6342		
MIXED			
Mixed Barsac	6487		
BORDEAUX RED			
1858			
Château Latour	6350		
1861			
Château Latour	6351		
1862			
Château Latour	6352		
1887			
Château Latour	6353		
1888			
Château Latour	6354		

Index by Vintage

WINE	Lot No.	WINE	Lot No.
2000		2006	
Château Mouton Rothschild	6011, 6195-6196	Château Latour	6010, 6193-6194
Château Lafleur	6024	Château Lafite-Rothschild	6123, 6177-6181
2001		Carruades De Lafite	6138
Château Lafleur	6025	Château Mouton Rothschild	6140, 6204-6211
Le Pin	6079	Château Pichon-Longueville, Lalande	6219
Château Lafite-Rothschild	6118	Château Pontet-Canet	6225-6228
Carruades De Lafite	6132	Château Ducru-Beaucaillou	6230-6232
2003		Château Léoville-Las-Cases	6238-6240
Château Mouton Rothschild	6012-6013, 6197-6201	Château Margaux	6243-6247
Château Cos d'Estournel	6164-6165	Château Haut-Brion	6264-6268
Château Pichon-Longueville, Lalande	6212-6215	Château La Mission-Haut-Brion	6270-6272
Château Pontet-Canet	6220-6222	Château L'Église Clinet	6282-6284
Château Ducru-Beaucaillou	6229	Château Cheval Blanc	6295-6298
Château Léoville-Las-Cases	6233-6237	Château Pavie	6304-6308
Château Haut-Brion	6254-6256	Château La Mondotte	6309-6310
Château Rol Valentin	6315-6317	Coffret Bordeaux Collection	6320
Château Valandraud	6318-6319	Duclot Collection	6346
Saint-Émilion	6493	2007	
2004		Château Lafite-Rothschild	6124-6126
Carruades De Lafite	6133-6135	Carruades De Lafite	6139
Château Lafite-Rothschild	6119-6121, 6172-6174	Château Cos d'Estournel	6371
Château Pichon-Longueville, Lalande	6216-6218	2008	
Château Lascombes	6248-6250	Château Haut-Brion	6017
Château Haut-Brion	6257-6262	Château Lafite-Rothschild	6182-6190
Le Pin	6276-6277	Coffret Corndale Collection	6321-6322
Château Clos L'Église	6278-6281	Duclot Collection	6347
Château Trotanoy	6286-6289	2009	
Château Cheval Blanc	6292	Château Lafite-Rothschild	6127-6129
Duclot Collection	6344	Château Cos d'Estournel	6372
2005		Château Ausone	6484-6485
Château Mouton Rothschild	6014, 6202-6203	Duclot Collection	6348
Château Haut-Brion	6016	2010	
Carruades De Lafite	6136-6137	Château Lafite-Rothschild	6130-6131
Château Lafite-Rothschild	6122, 6175-6176	Château Grand-Puy-Lacoste	6483
Château Cos d'Estournel	6166-6168	Duclot Collection	6349
Château Latour	6191-6192	MIXED	
Château Pontet-Canet	6223-6224	Mixed 2001 & 2006 Petrus	6077
Château Margaux	6241-6242	Mixed Château Lafleur 1996 & 1998	6081
Château Lascombes	6251-6253	Mixed Château Lafleur 1999 & 2004	6082
Château Haut-Brion	6263	Mixed 1952 Latour & La Tâche	6162
Château La Mission-Haut-Brion	6269	Mixed 1960s Château Latour	6362
Château Pape-Clément Rouge	6273-6274	Mixed 1970s Château Latour	6363
Château L'Évangile	6285	Mixed 1980s Château Latour	6364
Château Angéus	6290-6291	Mixed 1990s Château Latour	6365
Château Cheval Blanc	6293-6294	Mixed 1900s Château Latour	6356
Château Pavie	6299-6303	Mixed 1910s Château Latour	6357
Château Monbousquet	6311-6314	Mixed 1920s Château Latour	6358
Coffret Prestige Collection	6323-6324	Mixed 1930s Château Latour	6359
Duclot Collection	6345	Mixed 1940s Château Latour	6360

Index by Vintage

WINE	Lot No.	WINE	Lot No.
Mixed 1950s Château Latour	6361	1984	
Mixed 2000s Château Latour	6366	Henri Mayer, Echézeaux	6405
Château Latour Vertical Collection 1894 - 2008	6367	Henri Mayer, Vosne-Romanée Cros Parantoux	6412
Château Mouton Rothschild Vertical 1945-2005	6368	1985	
Château Mouton Rothschild Vertical		Georges et Henri Mayer, Echézeaux	6388
in Magnum 1974 - 2012	6369	Henri Mayer, Echézeaux	6406
Mixed Château Cos d'Estournel	6370	1986	
Mixed Cos d'Estournel	6373	Domaine de la Romanée-Conti, La Tâche	6384
Mixed Bordeaux Grand Cru Classé	6376	Henri Mayer, Echézeaux	6407
Mixed Ausone and Cheval Blanc	6377	Henri Mayer, Nuits-Saint-Georges Murgers	6409
Mixed Bordeaux	6417	Henri Mayer, Vosne-Romanée Cros Parantoux	6413
Mixed French	6419	Henri Mayer, Vosne-Romanée Les Brulées	6414
		Henri Mayer, Vosne-Romanée Les Beaux Monts	6415
BURGUNDY WHITE		1987	
1990		Henri Mayer, Echézeaux	6408
Leroy, Corton-Charlemagne	6071	1988	
1991		Domaine de la Romanée-Conti, Romanée-Conti	6038
Leroy, Corton-Charlemagne	6072	DRC Assortment	6086-6087
1999		Domaine de la Romanée-Conti, Romanée-Saint-Vivant	6385
Domaine des Comtes Lafon, Meursult-Charmes	6379	1989	
2000		DRC Assortment	6088-6089
d'Auvenay, Chevalier-Montrachet	6069	1990	
d'Auvenay, Puligny-Montrachet Les Folatières	6070	J.F. Mugnier, Musigny	6060
2004		Jacques-Frederic Mugnier, Musigny	6390
J. F.Coche-Dury, Corton-Charlemagne	6067	1991	
2010		La Tâche	6401
Etienne Sauzet, Montrachet	6494	1993	
MIXED		Méo-Camuzet, Nuits-Saint-Georges Les Boudots	6055
Mixed 1982 J.F.Coche-Dury	6416	J.F. Mugnier, Musigny	6061
		La Tâche	6402-6403
BURGUNDY RED		Gevrey-Chambertin Clos Saint-Jacques	6482
1959		1995	
Comte Georges de Vogue, Bonnes-Mares	6035	Mommessin, Clos de Tart	6058
1966		DRC Assortment	6090
La Tâche	6481	1996	
1972		A. Rousseau, Chambertin	6033
Domaine de la Romanée-Conti, Grands-Echézeaux	6386	Domaine de la Romanée-Conti, La Tâche	6041
1976		Leroy, Latricières-Chambertin	6050
Henri Mayer, Echézeaux	6387	Méo-Camuzet, Nuits-Saint-Georges Les Boudots	6056
1978		Domaine Leroy, Clos de Vougeot	6102
Henri Mayer, Echézeaux	6049	Henri Mayer, Vosne-Romanée Cros-Parantoux	6389
Domaine de la Romanée-Conti, Romanée-Saint-Vivant	6084	1999	
Maison Leroy, Mazis-Chambertin	6101	Comte Georges de Vogue, Musigny Vieilles Vignes	6036
1980		Domaine de la Romanée-Conti, La Tâche	6042
Henri Mayer, Echézeaux	6404	Leroy, Latricières-Chambertin	6051
Henri Mayer, Vosne-Romanée Cros Parantoux	6410	Méo-Camuzet, Nuits-Saint-Georges Les Boudots	6057
1981		Domaine Dugat-Py, Charmes-Chambertin	6095
Henri Mayer, Vosne-Romanée Cros Parantoux	6411	Mommessin, Clos de Tart	6396
1982			
Domaine de la Romanée-Conti, La Tâche	6040		

Index by Vintage

WINE	Lot No.	WINE	Lot No.
2000		2011	
Domaine de la Romanée-Conti, DRC Assortment	6047	Domaine Jean-Pierre Mathieu,	
DRC Assortment	6091	Charmes-Chambertin Aux Mazoyères	6064
Jacques-Frederic Mugnier, Musigny	6391	MIXED	
2001		Mixed A. Rousseau Chambertin &	
Domaine de la Romanée-Conti, Romanée-Conti	6039, 6383	Chambertin-Clos-de-Bèze 1969	6032
Domaine de la Romanée-Conti, La Tâche	6043	DRC Grands-Echézeaux Vertical	6094
Leroy, Latricières-Chambertin	6052	Mixed Charmes-Chambertin 2002 &	
DRC Assortment	6092	Mazis-Chambertin 2003 from Dugat-Py	6098
Domaine Dugat-Py, Charmes-Chambertin	6096	Mixed 1999 & 2001 Mazis-Chambertin from Dugat-Py	6099
2002		Mixed 2002 Mazis-Chambertin &	
Comte Georges de Vogue, Musigny Vieilles Vignes	6037	Charmes-Chambertin from Dugat-Py	6100
Domaine de la Romanée-Conti, La Tâche	6044	Mixed Burgundy	6397
Hubert Lignier, Clos de la Roche	6053	Mixed 1980 Lancart l'Aînée	6421
Méo-Camuzet, Clos Vougeot	6054	Mixed Domaine Faiveley, Chambertin-Clos-de-Bèze	6492
DRC Assortment	6093		
Domaine Leroy, Clos de Vougeot	6103-6104	RHÔNE	
Jacques-Frederic Mugnier, Musigny	6392	1990	
2003		Clos des Papes, Châteauneuf-du-Pape	6418
Domaine de la Romanée-Conti, Richebourg	6083	2003	
Domaine de la Romanée-Conti, Romanée-Saint-Vivant	6085	J.L. Chave, Ermitage Cuvée Cathelin	6073
Domaine Dugat-Py, Charmes-Chambertin	6097	J.L. Chave, Hermitage	6074
Mommessin, Clos de Tart	6112	MIXED	
Domaine G. Roumier, Bonnes-Mares	6380	Mixed Guigal	6398
2004		Mixed Rhône & Germany	6420
Domaine de la Romanée-Conti, La Tâche	6045	Mixed M. Chapoutier Ermitage	6423
G. Roumier, Bonnes-Mares	6065		
Domaine Leroy, Vosne-Romanée	6110-6111	ITALY	
Domaine G. Roumier, Bonnes-Mares	6381	2006	
2005		Sassicaia	6479-6480
A. Rousseau, Gevrey-Chambertin, Clos Saint-Jacques	6034	MIXED	
Mommessin, Clos de Tart	6059, 6113	Mixed Italy	6399
J.F. Mugnier, Musigny	6062	Mixed Ornellaia	6400
Domaine Leroy, Clos de Vougeot	6105		
Domaine Leroy, Nuits-Saint-Georges, Les Boudots	6106	DECANTER ASIA WINE AWARDS 2016	
Domaine Leroy, Vosne-Romanée, Les Beaux Monts	6107	Champagne	6424-6427
Jacques-Frederic Mugnier, Musigny	6393	Bordeaux	6428-6432
2006		Rhône	6433-6435
G. Roumier, Bonnes-Mares	6066	Tuscany	6436-6441
Domaine Leroy, Pommard Les Vignots	6108-6109	Piedmont	6442-6444
2007		Spain	6445-6452
Domaine de la Romanée-Conti, Richebourg	6046	Veneto	6453-6456
2009		Australia	6457-6466
Domaine de la Romanée-Conti, DRC Superlot	6048	New Zealand	6467-6471
Ponsot, Clos de la Roche Vieilles Vignes	6063	North America	6472-6474
Domaine G. Roumier, Morey-Saint-Denis		Gold and Regional Trophies	6475-6478
Clos de la Bussière	6382		
Jacques-Frederic Mugnier, Chambolle-Musigny	6394		
2010			
Jacques-Frederic Mugnier, Chambolle-Musigny	6395		

CONDITIONS OF SALE • BUYING AT CHRISTIE'S

CONDITIONS OF SALE

These Conditions of Sale and the Important Notices and Explanation of Cataloguing Practice set out the terms on which we offer the **lots** listed in this catalogue for sale. By registering to bid and/or by bidding at auction you agree to these terms, so you should read them carefully before doing so. You will find a glossary at the end explaining the meaning of the words and expressions coloured in **bold**.

Unless we own a **lot** (A symbol), Christie's acts as agent for the seller.

A BEFORE THE SALE

1 DESCRIPTION OF LOTS

(a) Certain words used in the catalogue description have special meanings. You can find details of these on the page headed "Important Notices and Explanation of Cataloguing Practice" which forms part of these terms. You can find a key to the Symbols found next to certain catalogue entries under the section of the catalogue called "Symbols Used in this Catalogue".

(b) Our description of any **lot** in the catalogue, any **condition** report and any other statement made by us (whether orally or in writing) about any **lot**, including about its nature or **condition**, artist, period, materials, approximate dimensions or **provenance** are our opinion and not to be relied upon as a statement of fact. We do not carry out in-depth research of the sort carried out by professional historians and scholars. All dimensions and weights are approximate only.

2 OUR RESPONSIBILITY FOR OUR DESCRIPTION OF LOTS

We do not provide any guarantee in relation to the nature of a **lot** apart from our **authenticity warranty** contained in paragraph E2 and to the extent provided in paragraph I below.

3 CONDITION

(a) The **condition** of **lots** sold in our auctions can vary widely due to factors such as age, previous damage, restoration, repair and wear and tear. Their nature means that they will rarely be in perfect **condition**. **Lots** are sold "as is" in the **condition** they are in at the time of the sale, without any representation or warranty or assumption of liability of any kind as to **condition** by Christie's or by the seller.

(b) Any reference to **condition** in a catalogue entry or in a **condition** report will not amount to a full description of **condition**, and images may not show a **lot** clearly. Colours and shades may look different in print or on screen to how they look on physical inspection. **Condition** reports may be available to help you evaluate the **condition** of a **lot**. **Condition** reports are provided free of charge as a convenience to our buyers and are for guidance only. They offer our opinion but they may not refer to all faults, inherent defects, restoration, alteration or adaptation because our staff are not professional restorers or conservators. For that reason they are not an alternative to examining a **lot** in person or taking your own professional advice. It is your responsibility to ensure that you have requested, received and considered any **condition** report.

4 VIEWING LOTS PRE-AUCTION

(a) If you are planning to bid on a **lot**, you should inspect it personally or through a knowledgeable representative before you make a bid to make sure that you accept the description and its **condition**. We recommend you get your own advice from a restorer or other professional adviser.

(b) Pre-auction viewings are open to the public free of charge. Our specialists may be available to answer questions at pre-auction viewings or by appointment.

5 ESTIMATES

Estimates are based on the **condition**, rarity, quality and **provenance** of the **lots** and on prices recently paid

at auction for similar property. **Estimates** can change. Neither you, nor anyone else, may rely on any **estimates** as a prediction or guarantee of the actual selling price of a **lot** or its value for any other purpose. **Estimates** do not include the **buyer's premium** or any applicable taxes.

6 WITHDRAWAL

Christie's may, at its option, withdraw any **lot** at any time prior to or during the sale of the **lot**. Christie's has no liability to you for any decision to withdraw.

7 JEWELLERY

(a) Coloured gemstones (such as rubies, sapphires and emeralds) may have been treated to improve their look, through methods such as heating and oiling. These methods are accepted by the international jewellery trade but may make the gemstone less strong and/or require special care over time.

(b) All types of gemstones may have been improved by some method. You may request a gemmological report for any item which does not have a report if the request is made to us at least three weeks before the date of the auction and you pay the fee for the report.

(c) We do not obtain a gemmological report for every gemstone sold in our auctions. Where we do get gemmological reports from internationally accepted gemmological laboratories, such reports will be described in the catalogue. Reports from American gemmological laboratories will describe any improvement or treatment to the gemstone. Reports from European gemmological laboratories will describe any improvement or treatment only if we request that they do so, but will confirm when no improvement or treatment has been made. Because of differences in approach and technology, laboratories may not agree whether a particular gemstone has been treated, the amount of treatment or whether treatment is permanent. The gemmological laboratories will only report on the improvements or treatments known to the laboratories at the date of the report.

(d) For jewellery sales, **estimates** are based on the information in any gemmological report or, if no report is available, assume that the gemstones may have been treated or enhanced.

8 WATCHES & CLOCKS

(a) Almost all clocks and watches are repaired in their lifetime and may include parts which are not original. We do not give a **warranty** that any individual component part of any watch is **authentic**. Watchbands described as "associated" are not part of the original watch and may not be **authentic**. Clocks may be sold without pendulums, weights or keys.

(b) As collectors' watches often have very fine and complex mechanisms, a general service, change of battery or further repair work may be necessary, for which you are responsible. We do not give a **warranty** that any watch is in good working order. Certificates are not available unless described in the catalogue.

(c) Most wristwatches have been opened to find out the type and quality of movement. For that reason, wristwatches with water resistant cases may not be waterproof and we recommend you have them checked by a competent watchmaker before use.

Important information about the sale, transport and shipping of watches and watchbands can be found in paragraph H2(g).

B REGISTERING TO BID

1 NEW BIDDERS

(a) If this is your first time bidding at Christie's or you are a returning bidder who has not bought anything from any of our salerooms within the last two years you must register at least 48 hours before an auction to give us enough time to process and approve your registration. We may, at our option, decline to permit you to register as a bidder. You will be asked for the following:

(i) for individuals: Photo identification (driving licence, national identity card or passport) and, if not shown on the ID document, proof of your current address (for example, a current utility bill or bank statement);

(ii) for corporate clients: Your Certificate of Incorporation or equivalent document(s) showing your name and registered address together with documentary proof of directors and beneficial owners; and

(iii) for trusts, partnerships, offshore companies and other business structures, please contact us in advance to discuss our requirements.

(b) We may also ask you to give us a financial reference and/or a deposit as a condition of allowing you to bid. For help, please contact our Client Services Department on +852 2760 1766.

2 RETURNING BIDDERS

We may at our option ask you for current identification as described in paragraph B1(a) above, a financial reference or a deposit as a condition of allowing you to bid. If you have not bought anything from any of our salerooms in the last two years or if you want to spend more than on previous occasions, please contact our Bids Department on +852 2978 9910 or email to bidsasia@christies.com.

3 IF YOU FAIL TO PROVIDE THE RIGHT DOCUMENTS

If in our opinion you do not satisfy our bidder identification and registration procedures including, but not limited to completing any anti-money laundering and/or anti-terrorism financing checks we may require to our satisfaction, we may refuse to register you to bid, and if you make a successful bid, we may cancel the contract for sale between you and the seller.

4 BIDDING ON BEHALF OF ANOTHER PERSON

(a) **As authorised bidder:** If you are bidding on behalf of another person, that person will need to complete the registration requirements above before you can bid, and supply a signed letter authorising you to bid for him/her.

(b) **As agent for an undisclosed principal:** If you are bidding as an agent for an undisclosed principal (the ultimate buyer(s)), you accept personal liability to pay the **purchase price** and all other sums due. Further, you warrant that:

(i) you have conducted appropriate customer due diligence on the ultimate buyer(s) of the **lot(s)** in accordance with any and all applicable anti-money laundering and sanctions laws, consent to us relying on this due diligence, and you will retain for a period of not less than 5 years the documentation and records evidencing the due diligence;

(ii) you will make such documentation and records evidencing your due diligence promptly available for immediate inspection by an independent third-party auditor upon our written request to do so. We will not disclose such documentation and records to any third-parties unless (1) it is already in the public domain, (2) it is required to be disclosed by law, or (3) it is in accordance with anti-money laundering laws;

(iii) the arrangements between you and the ultimate buyer(s) are not designed to facilitate tax crimes;

(iv) you do not know, and have no reason to suspect, that the funds used for settlement are connected with, the proceeds of any criminal activity or that the ultimate buyer(s) are under investigation, charged with or convicted of money laundering, terrorist activities or other money laundering predicate crimes.

A bidder accepts personal liability to pay the **purchase price** and all other sums due unless it has been agreed in writing with Christie's before commencement of the auction that the bidder is acting as an agent on behalf of a named third party acceptable to Christie's and that Christie's will only seek payment from the named third party.

5 BIDDING IN PERSON

If you wish to bid in the saleroom you must register for a numbered bidding paddle at least 30 minutes before the auction. For help, please contact the Client Services Department on +852 2760 1766.

6 BIDDING SERVICES

The bidding services described below are a free service offered as a convenience to our clients and Christie's is not responsible for any error (human or otherwise), omission or breakdown in providing these services.

(A) PHONE BIDS

Your request for this service must be made no later than 24 hours prior to the auction. We will accept bids by telephone for **lots** only if our staff are available to take the bids. Telephone bids cannot be accepted for lots estimated below HK\$30,000. If you need to bid in a language other than in English, you must arrange this well before the auction. We may record telephone bids. By bidding on the telephone, you are agreeing to us recording your conversations. You also agree that your telephone bids are governed by these Conditions of Sale.

(B) INTERNET BIDS ON CHRISTIE'S LIVE™

For certain auctions we will accept bids over the Internet. Please visit www.christies.com/livebidding and click on the 'Bid Live' icon to see details of how to watch, hear and bid at the auction from your computer. As well as these Conditions of Sale, internet bids are governed by the Christie's LIVE™ terms of use which are available on www.christies.com.

(C) WRITTEN BIDS

You can find a Written Bid Form at the back of our catalogues, at any Christie's office or by choosing the sale and viewing the **lots** online at www.christies.com. We must receive your completed Written Bid Form at least 24 hours before the auction. Bids must be placed in the currency of the saleroom. The auctioneer will take reasonable steps to carry out written bids at the lowest possible price, taking into account the **reserve**. If you make a written bid on a **lot** which does not have a **reserve** and there is no higher bid than yours, we will bid on your behalf at around 50% of the **low estimate** or, if lower, the amount of your bid. If we receive written bids on a **lot** for identical amounts, and at the auction these are the highest bids on the **lot**, we will sell the **lot** to the bidder whose written bid we received first.

C AT THE SALE

1 WHO CAN ENTER THE AUCTION

We may, at our option, refuse admission to our premises or decline to permit participation in any auction or to reject any bid.

2 RESERVES

Unless otherwise indicated, all **lots** are subject to a **reserve**. We identify **lots** that are offered without **reserve** with the symbol · next to the **lot** number. The **reserve** cannot be more than the **lot's low estimate**.

3 AUCTIONEER'S DISCRETION

The auctioneer can at his sole option:

- refuse any bid;
- move the bidding backwards or forwards in any way he or she may decide, or change the order of the **lots**;
- withdraw any **lot**;
- divide any **lot** or combine any two or more **lots**;
- reopen or continue the bidding even after the hammer has fallen; and
- in the case of error or dispute and whether during or after the auction, to continue the bidding, determine the successful bidder, cancel the sale of the **lot**, or reoffer and resell any **lot**. If any dispute relating to bidding arises during or after the auction, the auctioneer's decision in exercise of this option is final.

4 BIDDING

The auctioneer accepts bids from:

- bidders in the saleroom;
- telephone bidders, and internet bidders through 'Christie's LIVE™' (as shown above in Section B6); and

(c) written bids (also known as absentee bids or commission bids) left with us by a bidder before the auction.

5 BIDDING ON BEHALF OF THE SELLER

The auctioneer may, at his or her sole option, bid on behalf of the seller up to but not including the amount of the **reserve** either by making consecutive bids or by making bids in response to other bidders. The auctioneer will not identify these as bids made on behalf of the seller and will not make any bid on behalf of the seller at or above the **reserve**. If **lots** are offered without **reserve**, the auctioneer will generally decide to open the bidding at 50% of the **low estimate** for the **lot**. If no bid is made at that level, the auctioneer may decide to go backwards at his or her sole option until a bid is made, and then continue up from that amount. In the event that there are no bids on a **lot**, the auctioneer may deem such **lot** unsold.

6 BID INCREMENTS

Bidding generally starts below the **low estimate** and increases in steps (bid increments). The auctioneer will decide at his or her sole option where the bidding should start and the bid increments. The usual bid increments are shown for guidance only on the Written Bid Form at the back of this catalogue.

7 CURRENCY CONVERTER

The saleroom video screens (and Christie's LIVETM) may show bids in some other major currencies as well as Hong Kong dollar. Any conversion is for guidance only and we cannot be bound by any rate of exchange used. Christie's is not responsible for any error (human or otherwise), omission or breakdown in providing these services.

8 SUCCESSFUL BIDS

Unless the auctioneer decides to use his or her discretion as set out in paragraph C3 above, when the auctioneer's hammer strikes, we have accepted the last bid. This means a contract for sale has been formed between the seller and the successful bidder. We will issue an invoice only to the registered bidder who made the successful bid. While we send out invoices by post and/or email after the auction, we do not accept responsibility for telling you whether or not your bid was successful. If you have bid by written bid, you should contact us by telephone or in person as soon as possible after the auction to get details of the outcome of your bid to avoid having to pay unnecessary storage charges.

9 LOCAL BIDDING LAWS

You agree that when bidding in any of our sales that you will strictly comply with all local laws and regulations in force at the time of the sale for the relevant sale site.

D THE BUYER'S PREMIUM, TAXES

1 THE BUYER'S PREMIUM

In addition to the **hammer price**, the successful bidder agrees to pay us a **buyer's premium** on the **hammer price** of each **lot** sold. On all **lots** we charge 25% of the **hammer price** up to and including HK\$1,200,000, 20% on that part of the **hammer price** over HK\$1,200,000 and up to and including HK\$20,000,000, and 12% of that part of the **hammer price** above HK\$20,000,000.

For wine there is a flat rate of 22.5% of the **hammer price** of each **lot** sold.

2 TAXES

The successful bidder is responsible for any applicable tax including any VAT, sales or compensating use tax or equivalent tax wherever they arise on the **hammer price** and the **buyer's premium**. It is the buyer's responsibility to ascertain and pay all taxes due. In all circumstances Hong Kong law takes precedence.

E WARRANTIES

1 SELLER'S WARRANTIES

For each **lot**, the seller gives a **warranty** that the seller: (a) is the owner of the **lot** or a joint owner of the **lot** acting with the permission of the other co-owners or, if

the seller is not the owner or a joint owner of the **lot**, has the permission of the owner to sell the **lot**, or the right to do so in law; and

(b) has the right to transfer ownership of the **lot** to the buyer without any restrictions or claims by anyone else. If either of the above **warranties** are incorrect, the seller shall not have to pay more than the **purchase price** (as defined in paragraph F1(a) below) paid by you to us. The seller will not be responsible to you for any reason for loss of profits or business, expected savings, loss of opportunity or interest, costs, damages, **other damages** or expenses. The seller gives no **warranty** in relation to any **lot** other than as set out above and, as far as the seller is allowed by law, all **warranties** from the seller to you, and all other obligations upon the seller which may be added to this agreement by law, are excluded.

2 OUR AUTHENTICITY WARRANTY

We warrant, subject to the terms below, that the **lots** in our sales are **authentic** (our "**authenticity warranty**"). If, within 5 years of the date of the auction, you satisfy us that your **lot** is not **authentic**, subject to the terms below, we will refund the **purchase price** paid by you. The meaning of **authentic** can be found in the glossary at the end of these Conditions of Sale. The terms of the **authenticity warranty** are as follows:

(a) It will be honoured for a period of 5 years from the date of the auction. After such time, we will not be obligated to honour the **authenticity warranty**.
(b) It is given only for information shown in **UPPERCASE type** in the first line of the **catalogue description** (the "**Heading**"). It does not apply to any information other than in the **Heading** even if shown in **UPPERCASE type**.

(c) The **authenticity warranty** does not apply to any **Heading** or part of a **Heading** which is **qualified**. **Qualified** means limited by a clarification in a **lot's catalogue description** or by the use in a **Heading** of one of the terms listed in the section titled **Qualified Headings** on the page of the catalogue headed "Important Notices and Explanation of Cataloguing Practice". For example, use of the term "ATTRIBUTED TO..." in a **Heading** means that the **lot** is in Christie's opinion probably a work by the named artist but no **warranty** is provided that the **lot** is the work of the named artist. Please read the full list of **Qualified Headings** and a **lot's full catalogue description** before bidding.

(d) The **authenticity warranty** applies to the **Heading** as amended by any **Saleroom Notice**.

(e) The **authenticity warranty** does not apply where scholarship has developed since the auction leading to a change in generally accepted opinion. Further, it does not apply if the **Heading** either matched the generally accepted opinion of experts at the date of the sale or drew attention to any conflict of opinion.

(f) The **authenticity warranty** does not apply if the **lot** can only be shown not to be **authentic** by a scientific process which, on the date we published the catalogue, was not available or generally accepted for use, or which was unreasonably expensive or impractical, or which was likely to have damaged the **lot**.

(g) The benefit of the **authenticity warranty** is only available to the original buyer shown on the invoice for the **lot** issued at the time of the sale and only if the original buyer has owned the **lot** continuously between the date of the auction and the date of claim. It may not be transferred to anyone else.

(h) In order to claim under the **authenticity warranty** you must:

- give us written details, including full supporting evidence, of any claim within 5 years of the date of the auction;
 - at Christie's option, we may require you to provide the written opinions of two recognised experts in the field of the **lot** mutually agreed by you and us in advance confirming that the **lot** is not **authentic**. If we have any doubts, we reserve the right to obtain additional opinions at our expense; and
 - return the **lot** at your expense to the saleroom from which you bought it in the **condition** it was in at the time of sale.
- (i) Your only right under this **authenticity warranty** is to cancel the sale and receive a refund of the

purchase price paid by you to us. We will not, in any circumstances, be required to pay you more than the **purchase price** nor will we be liable for any loss of profits or business, loss of opportunity or value, expected savings or interest, costs, damages, **other damages** or expenses.

(j) **Books.** Where the **lot** is a book, we give an additional **warranty** for 14 days from the date of the sale that if on collation any **lot** is defective in text or illustration, we will refund your **purchase price**, subject to the following terms:

- (a) This additional **warranty** does not apply to:
 - (i) the absence of blanks, half titles, tissue guards or advertisements, damage in respect of bindings, stains, spotting, marginal tears or other defects not affecting completeness of the text or illustration;
 - (ii) drawings, autographs, letters or manuscripts, signed photographs, music, atlases, maps or periodicals;
 - (iii) books not identified by title;
 - (iv) **lots** sold without a printed **estimate**;
 - (v) books which are described in the catalogue as sold not subject to return; or
 - (vi) defects stated in any **condition** report or **announcement** at the time of sale.
- (b) To make a claim under this paragraph you must give written details of the defect and return the **lot** to the sale room at which you bought it in the same **condition** as at the time of sale, within 14 days of the date of the sale.

(k) **South East Asian Modern and Contemporary Art and Chinese Calligraphy and Painting.**

In these categories, the **authenticity warranty** does not apply because current scholarship does not permit the making of definitive statements. Christie's does, however, agree to cancel a sale in either of these two categories of art where it has been proven the **lot** is a forgery. Christie's will refund to the original buyer the **purchase price** in accordance with the terms of Christie's **authenticity warranty**, provided that the original buyer notifies us with full supporting evidence documenting the forgery claim within twelve (12) months of the date of the auction. Such evidence must be satisfactory to us that the **lot** is a forgery in accordance with paragraph E2(h)(ii) above and the **lot** must be returned to us in accordance with E2h(ii) above. Paragraphs E2(b), (c), (d), (e), (f) and (g) and (i) also apply to a claim under these categories.

(l) **GUARANTEE IN RELATION TO WINES AND SPIRITS**

(a) Subject to the obligations accepted by Christie's, none of the seller, Christie's, its employees or agents is responsible for the correctness of any statement as to the authorship, origin, date, age, attribution, genuineness or provenance of any **lot**, for any other error of description of for any fault or defect in any **lot** and no warranty whatsoever is given by the seller, Christie's, its employees or agents in respect of any **lot** and any express or implied condition or warranty is hereby excluded;

(b) If, (1) within twenty-one days of the date of the auction, Christie's has received notice in writing from the buyer of any **lot** that in his view the **lot** was at the date of the auction short or ullaged or that any statement of opinion in the catalogue was not well founded, (2) within fourteen days of such notice, Christie's has the **lots** in its possession in the same condition as at the date of the auction and (3) within a reasonable time thereafter, the buyer satisfies Christie's that the **lot** was as notified in writing by the buyer (as above) and that the buyer is able to transfer a good and marketable title to the **lot** free from any lien or encumbrance, Christie's will set aside the sale and refund to the buyer any amount paid by the buyer in respect of the **lot** provided that the buyer shall have no rights under this Condition if:

- (i) the defect is mentioned in the catalogue; or
- (ii) the catalogue description at the date of the auction was in accordance with the then generally accepted opinion of scholars or experts or fairly indicated there to be a conflict of such opinion; or
- (iii) it can be established that the **lot** was as notified in writing by the buyer (as above) only by means of a

scientific process not generally accepted for use until after the publication of the catalogue or by means of a process which at the date of the auction was unreasonably expensive or impracticable or likely to have caused damage to the **lot**. (See also notes on ullages and corks);

(c) the buyer shall not be entitled to claim under this Condition for more than the amount paid by him for the **lot** and in particular shall have no claim for any loss, consequential loss or damage whether direct or indirect suffered by him;

(d) the benefit of this guarantee shall not be assignable and shall rest solely and exclusively in the buyer who shall be the person to whom the original invoice was made out by Christie's in respect of the **lot** when sold and who has since the sale retained uninterrupted, unencumbered ownership thereof.

F PAYMENT

1 HOW TO PAY

(a) Immediately following the auction, you must pay the **purchase price** being:

- (i) the **hammer price**; and
- (ii) the **buyer's premium**; and
- (iii) any duties, goods, sales, use, compensating or service tax.

Payment is due no later than by the end of the 7th calendar day following the date of the auction (the "**due date**").

(b) We will only accept payment from the registered bidder. Once issued, we cannot change the buyer's name on an invoice or re-issue the invoice in a different name. You must pay immediately even if you want to export the **lot** and you need an export licence.

(c) You must pay for **lots** bought at Christie's in Hong Kong in the currency stated on the invoice in one of the following ways:

- (i) Wire transfer
- You must make payments to:

HSBC
Head Office
1 Queen's Road, Central, Hong Kong
Bank code: 004
Account No. 062-305438-001
Account Name: Christie's Hong Kong Limited
SWIFT: HSBCHKHHHKH

(ii) Credit Card.

We accept most major credit cards subject to certain conditions. We accept payments in person by credit card up to HK\$1,000,000 per auction sale although conditions and restrictions apply. China Union Pay is accepted with no limits on amounts. To make a "cardholder not present" (CNP) payment, we accept payment up to HK\$500,000 per auction sale. You must complete a CNP authorisation form which you can get from our Post-Sale Services Department. You must send a completed CNP authorisation form by fax to +852 2973 0111 or by post to the address set out in paragraph (d) below. CNP payments cannot be accepted by all salerooms and are subject to certain restrictions. Details of the conditions and restrictions applicable to credit card payments are available from our Post-Sale Services Department, whose details are set out in paragraph (d) below.

(iii) Cash

We accept cash subject to a maximum of HKD80,000 per buyer per year at our Post-Sale Services Department only (subject to conditions).

(iv) Banker's draft

You must make these payable to Christie's Hong Kong Limited and there may be conditions.

(v) Cheque

You must make cheques payable to Christie's Hong Kong Limited. Cheques must be from accounts in Hong Kong dollar from a Hong Kong bank.

(d) You must quote the sale number, your invoice number and client number when making a payment. All payments sent by post must be sent to: Christie's, Post-Sale Services Department, 22nd Floor Alexandra House, 18 Chater Road, Central, Hong Kong.

(e) For more information please contact our Post-Sale Services Department by phone on +852 2760 1766 or fax on +852 2973 0111.

2 TRANSFERRING OWNERSHIP TO YOU

You will not own the **lot** and ownership of the **lot** will not pass to you until we have received full and clear payment of the **purchase price**, even in circumstances where we have released the **lot** to the buyer.

3 TRANSFERRING RISK TO YOU

The risk in and responsibility for the **lot** will transfer to you from whichever is the earlier of the following:

- (a) When you collect the **lot**; or
- (b) At the end of the 7th day following the date of the auction, if earlier, the date the **lot** is taken into care by a third party warehouse as set out on the page headed 'Christie's Hong Kong Wine Collection and Storage', unless we have agreed otherwise with you in writing.

4 WHAT HAPPENS IF YOU DO NOT PAY

(a) If you fail to pay us the **purchase price** in full by the **due date**, we will be entitled to do one or more of the following (as well as enforce our rights under paragraph F5 and any other rights or remedies we have by law):

- (i) to charge interest from the due date at a rate of 7% a year above the 3-month HIBOR rate from time to time on the unpaid amount due;
- (ii) we can cancel the sale of the **lot**. If we do this, we may sell the **lot** again, publicly or privately on such terms we shall think necessary or appropriate, in which case you must pay us any shortfall between the **purchase price** and the proceeds from the resale. You must also pay all costs, expenses, losses, damages and legal fees we have to pay or may suffer and any shortfall in the seller's commission on the resale;
- (iii) we can pay the seller an amount up to the net proceeds payable in respect of the amount bid by your default in which case you acknowledge and understand that Christie's will have all of the rights of the seller to pursue you for such amounts;
- (iv) we can hold you legally responsible for the **purchase price** and may begin legal proceedings to recover it together with other losses, interest, legal fees and costs as far as we are allowed by law;
- (v) we can take what you owe us from any amounts which we or any company in the **Christie's Group** may owe you (including any deposit or other part-payment which you have paid to us);
- (vi) we can, at our option, reveal your identity and contact details to the seller;
- (vii) we can reject at any future auction any bids made by you or on your behalf or to obtain a deposit from you before accepting any bids;
- (viii) to exercise all the rights and remedies of a person holding security over any property in our possession owned by you, whether by way of pledge, security interest or in any other way as permitted by the law of the place where such property is located. You will be deemed to have granted such security to us and we may retain such property as collateral security for your obligations to us; and
- (ix) we can take any other action we see necessary or appropriate.

(b) If you owe money to us or to another **Christie's Group** company, we can use any amount you do pay, including any deposit or other part-payment you have made to us, or which we owe you, to pay off any amount you owe to us or another **Christie's Group** company for any transaction.

(c) If you make payment in full after the **due date**, and we choose to accept such payment we may charge you storage and transport costs from the date that is 35 calendar days following the auction in accordance with paragraphs G(d) (i).

5 KEEPING YOUR PROPERTY

If you owe money to us or to another **Christie's Group** company, as well as the rights set out in F4 above, we can use or deal with any of your property we hold or which is held by another **Christie's Group** company in any way we are allowed to by law. We will only release

your property to you after you pay us or the relevant **Christie's Group** company in full for what you owe. However, if we choose, we can also sell your property in any way we think appropriate. We will use the proceeds of the sale against any amounts you owe us and we will pay any amount left from that sale to you. If there is a shortfall, you must pay us any difference between the amount we have received from the sale and the amount you owe us.

G COLLECTION AND STORAGE

(a) We ask that you collect purchased lots promptly following the auction (**but note that you may not collect any lot until you have made full and clear payment of all amounts due to us**).

(b) Information on collecting **lots** is set out on the Christie's Hong Kong Wine Collection and Storage page.

(c) If you do not collect a **lot** within the period set out in Christie's Hong Kong Wine Collection and Storage page then, unless otherwise agreed in writing:

(i) we will charge you storage costs from that date.

(ii) we may sell the **lot** in any commercially reasonable way we think appropriate.

(iii) Nothing in this paragraph is intended to limit our rights under paragraph F4.

H TRANSPORT AND SHIPPING

1 TRANSPORT AND SHIPPING

We will enclose a transport and shipping form with each invoice sent to you. You must make all transport and shipping arrangements. However, we can arrange to pack, transport and ship your property if you ask us to and pay the costs of doing so. We recommend that you ask us for an **estimate**, especially for any large items or items of high value that need professional packing before you bid. We may also suggest other handlers, packers, transporters or experts if you ask us to do so. For more information, please contact Post-Sale Services Department on +852 2760 1766 or email to postsalesia@christies.com. We will take reasonable care when we are handling, packing, transporting and shipping a **lot**. However, if we recommend another company for any of these purposes, we are not responsible for their acts, failure to act or neglect.

2 EXPORT AND IMPORT

Any **lot** sold at auction may be affected by laws on exports from the country in which it is sold and the import restrictions of other countries. Many countries require a declaration of export for property leaving the country and/or an import declaration on entry of property into the country. Local laws may prevent you from importing a **lot** or may prevent you selling a **lot** in the country you import it into.

(a) You alone are responsible for getting advice about and meeting the requirements of any laws or regulations which apply to exporting or importing any **lot** prior to bidding. If you are refused a licence or there is a delay in getting one, you must still pay us in full for the **lot**. We may be able to help you apply for the appropriate licences if you ask us to and pay our fee for doing so. However, we cannot guarantee that you will get one. For more information, please contact Post-Sale Services Department on +852 2760 1766 or email to postsalesia@christies.com.

(b) Lots made of protected species

Lots made of or including (regardless of the percentage) endangered and other protected species of wildlife are marked with the symbol - in the catalogue. This material includes, among other things, ivory, tortoiseshell, crocodile skin, rhinoceros horn, whalebone certain species of coral, and Brazilian rosewood. You should check the relevant customs laws and regulations before bidding on any **lot** containing wildlife material if you plan to import the **lot** into another country. Several countries refuse to allow you to import property containing these materials, and some other countries require a licence from the relevant regulatory agencies in the countries of exportation as well as importation. In some cases, the **lot** can only be shipped with an

independent scientific confirmation of species and/or age and you will need to obtain these at your own cost. If a **lot** contains elephant ivory, or any other wildlife material that could be confused with elephant ivory, (for example, mammoth ivory, walrus ivory, helmeted hornbill ivory) please see further important information in paragraph (c) if you are proposing to import the **lot** into the USA. We will not be obliged to cancel your purchase and refund the **purchase price** if your **lot** may not be exported, imported or it is seized for any reason by a government authority. It is your responsibility to determine and satisfy the requirements of any applicable laws or regulations relating to the export or import of property containing such protected or regulated material.

(c) US import ban on African elephant ivory

The USA prohibits the import of ivory from the African elephant. Any **lot** containing elephant ivory or other wildlife material that could be easily confused with elephant ivory (for example, mammoth ivory, walrus ivory, helmeted hornbill ivory) can only be imported into the US with results of a rigorous scientific test acceptable to Fish & Wildlife, which confirms that the material is not African elephant ivory. Where we have conducted such rigorous scientific testing on a **lot** prior to sale, we will make this clear in the lot description. In all other cases, we cannot confirm whether a **lot** contains African elephant ivory, and you will buy that **lot** at your own risk and be responsible for any scientific test or other reports required for import into the USA at your own cost. If such scientific test is inconclusive or confirms the material is from the African elephant, we will not be obliged to cancel your purchase and refund the **purchase price**.

(d) Lots of Iranian origin

Some countries prohibit or restrict the purchase and/or import of Iranian-origin "works of conventional craftsmanship" (works that are not by a recognized artist and/or that have a function, for example: carpets, bowls, ewers, tiles, ornamental boxes). For example, the USA prohibits the import of this type of property and its purchase by US persons (wherever located). Other countries, such as Canada, only permit the import of this property in certain circumstances. As a convenience to buyers, Christie's indicates under the title of a **lot** if the **lot** originates from Iran (Persia). It is your responsibility to ensure you do not bid on or import a **lot** in contravention of the sanctions or trade embargoes that apply to you.

(e) Gold

Gold of less than 18ct does not qualify in all countries as 'gold' and may be refused import into those countries as 'gold'.

(f) Watches

(i) Many of the watches offered for sale in this catalogue are pictured with straps made of endangered or protected animal materials such as alligator or crocodile. These **lots** are marked with the symbol - in the catalogue. These endangered species straps are shown for display purposes only and are not for sale. Christie's will remove and retain the strap prior to shipment from the sale site. At some sale sites, Christie's may, at its discretion, make the displayed endangered species strap available to the buyer of the **lot** free of charge if collected in person from the sale site within 1 year of the date of the sale. Please check with the department for details on a particular **lot**.

For all symbols and other markings referred to in paragraph H2, please note that **lots** are marked as a convenience to you, but we do not accept liability for errors or for failing to mark **lots**.

I OUR LIABILITY TO YOU

(a) We give no **warranty** in relation to any statement made, or information given, by us or our representatives or employees, about any **lot** other than as set out in the **authenticity warranty** and, as far as we are allowed by law, all **warranties** and other terms which may be added to this agreement by law are excluded. The seller's **warranties** contained in paragraph E1 are their own and we do not have any liability to you in relation to those **warranties**.

(b) (i) We are not responsible to you for any reason (whether for breaking this agreement or any other matter relating to your purchase of, or bid for, any **lot**) other than in the event of fraud or fraudulent misrepresentation by us or other than as expressly set out in these conditions of sale; or

(ii) give any representation, warranty or guarantee or assume any liability of any kind in respect of any **lot** with regard to merchantability, fitness for a particular purpose, description, size, quality, condition, attribution, authenticity, rarity, importance, medium, provenance, exhibition history, literature, or historical relevance. Except as required by local law, any warranty of any kind is excluded by this paragraph.

(c) In particular, please be aware that our written and telephone bidding services, Christie's LIVE™, condition reports, currency converter and saleroom video screens are free services and we are not responsible to you for any error (human or otherwise), omission, breakdown, or delay, unavailability, suspension or termination of any of these services.

(d) We have no **responsibility** to any person other than a buyer in connection with the purchase of any **lot**.

(e) If, in spite of the terms in paragraphs (a) to (d) or E2(i) above, we are found to be liable to you for any reason, we shall not have to pay more than the **purchase price** paid by you to us. We will not be responsible to you for any reason for loss of profits or business, loss of opportunity or value, expected savings or interest, costs, damages, or expenses.

J OTHER TERMS

1 OUR ABILITY TO CANCEL

In addition to the other rights of cancellation contained in this agreement, we can cancel a sale of a **lot** if we reasonably believe that completing the transaction is, or may be, unlawful or that the sale places us or the seller under any liability to anyone else or may damage our reputation.

2 RECORDINGS

We may videotape and record proceedings at any auction. We will keep any personal information confidential, except to the extent disclosure is required by law. However, we may, through this process, use or share these recordings with another **Christie's Group** company and marketing partners to analyse our customers and to help us to tailor our services for buyers. If you do not want to be videotaped, you may make arrangements to make a telephone or written bid or bid on Christie's LIVE™ instead. Unless we agree otherwise in writing, you may not videotape or record proceedings at any auction.

3 COPYRIGHT

We own the copyright in all images, illustrations and written material produced by or for us relating to a **lot** (including the contents of our catalogues unless otherwise noted in the catalogue). You cannot use them without our prior written permission. We do not offer any guarantee that you will gain any copyright or other reproduction rights to the **lot**.

4 ENFORCING THIS AGREEMENT

If a court finds that any part of this agreement is not valid or is illegal or impossible to enforce, that part of the agreement will be treated as being deleted and the rest of this agreement will not be affected.

5 TRANSFERRING YOUR RIGHTS AND RESPONSIBILITIES

You may not grant a security over or transfer your rights or responsibilities under these terms on the contract of sale with the buyer unless we have given our written permission. This agreement will be binding on your successors or estate and anyone who takes over your rights and responsibilities.

6 TRANSLATIONS

If we have provided a translation of this agreement, we will use the English version in deciding any issues or disputes which arise under this agreement.

7 PERSONAL INFORMATION

We will hold and process your personal information and may pass it to another **Christie's Group** company for use as described in, and in line with, our privacy policy at www.christies.com.

8 WAIVER

No failure or delay to exercise any right or remedy provided under these Conditions of Sale shall constitute a waiver of that or any other right or remedy, nor shall it prevent or restrict the further exercise of that or any other right or remedy. No single or partial exercise of such right or remedy shall prevent or restrict the further exercise of that or any other right or remedy.

9 LAW AND DISPUTES

The rights and obligations of the parties with respect to these Conditions of Sale, the conduct of the auction and any matters connected with any of the foregoing shall be governed and interpreted by the Hong Kong laws. By bidding at auction, whether present in person or by agent, by written bid, telephone or other means, the buyer shall be deemed to have accepted these Conditions and submitted, for the benefit of Christie's, to the exclusive jurisdiction of the Hong Kong courts, and also accepted that Christie's also has the right to pursue remedies in any other jurisdiction in order to recover any outstanding sums due from the buyer.

10 REPORTING ON WWWCHRISTIES.COM

Details of all **lots** sold by us, including **catalogue descriptions** and prices, may be reported on www.christies.com. Sales totals are **hammer price** plus **buyer's premium** and do not reflect costs, financing fees, or application of buyer's or seller's credits. We regret that we cannot agree to requests to remove these details from www.christies.com.

K GLOSSARY

authentic : a genuine example, rather than a copy or forgery of:

- (i) the work of a particular artist, author or manufacturer, if the **lot** is described in the **Heading** as the work of that artist, author or manufacturer;
- (ii) a work created within a particular period or culture, if the **lot** is described in the **Heading** as a work created during that period or culture;
- (iii) a work for a particular origin source if the **lot** is described in the **Heading** as being of that origin or source; or
- (iv) in the case of gems, a work which is made of a particular material, if the **lot** is described in the **Heading** as being made of that material.

authenticity warranty : the guarantee we give in this agreement that a **lot** is **authentic** as set out in section E2 of this agreement.

buyer's premium : the charge the buyer pays us along with the **hammer price**.

catalogue description : the description of a **lot** in the catalogue for the auction, as amended by any saleroom notice.

Christie's Group : Christie's International Plc, its subsidiaries and other companies within its corporate group.

condition : the physical **condition** of a **lot**.

due date : has the meaning given to it paragraph F1(a).

estimate : the price range included in the catalogue or any saleroom notice within which we believe a **lot** may sell. **Low estimate** means the lower figure in the range and **high estimate** means the higher figure. The **mid estimate** is the midpoint between the two.

hammer price : the amount of the highest bid the auctioneer accepts for the sale of a **lot**.

Heading : has the meaning given to it in paragraph E2.

lot : an item to be offered at auction (or two or more items to be offered at auction as a group).

other damages : any special, consequential, incidental or indirect damages of any kind or any damages which fall within the meaning of 'special', 'incidental' or 'consequential' under local law.

purchase price : has the meaning given to it in paragraph F1(a).

provenance : the ownership history of a **lot**.

qualified : has the meaning given to it in paragraph E2 and **Qualified Headings** means the section headed **Qualified Headings** on the page of the catalogue headed 'Important Notices and Explanation of Cataloguing Practice'.

reserve : the confidential amount below which we will not sell a **lot**.

saleroom notice : a written notice posted next to the **lot** in the saleroom and on www.christies.com, which is also read to prospective telephone bidders and notified to clients who have left commission bids, or an announcement made by the auctioneer either at the beginning of the sale, or before a particular **lot** is auctioned.

UPPER CASE type : means having all capital letters.

warranty : a statement or representation in which the person making it guarantees that the facts set out in it are correct.

業務規定

業務規定和重要通知及目錄編列方法之說明列明佳士得拍賣刊載在本目錄中**拍賣品**的條款。

通過登記報投和/或在拍賣會中競投即表示您同意接受這些條款，因此，您須在競投之前仔細閱讀這些條款。下述粗體字體詞語的解釋在尾部詞匯表列明。

除非佳士得擁有**拍賣品**所有權(以▲標示)，佳士得為賣方的代理人。

A. 拍賣之前

1. 拍賣品描述

- 目錄描述部分使用的某些詞匯有特殊意義。詳情請見構成條款部分的重要通知及目錄編列方法之說明。對目錄內的標識的解釋，請見本目錄內“本目錄中使用的各類標識”。
- 本公司在本目錄中對**拍賣品**的描述，**拍賣品狀況**報告及其陳述(不管管口頭還是書面)，包括**拍賣品**性質或**狀況**、藝術家、時期、材料、概略尺寸或**來源**均屬我們意見之表述，而不應被作為事實之陳述。我們不像專業的歷史學家及學者那樣進行深入的研究。所有的尺寸及重量僅為粗略估計。

2. 對於**拍賣品**描述佳士得所負的責任

我們不對**拍賣品**的性質提供任何保证，除了下述第 E2 段的**真品保證**以及第 I 段另有約定。

3. 狀況

- 在我們拍賣會上拍賣的**拍賣品狀況**可因年代、先前損壞、修復、修復及損耗等因素而差異甚大。其性質即意味著幾乎不可能處於完美的**狀況**。**拍賣品**是按照其在拍賣之時的情況以“現狀”出售，而且不包括佳士得或賣方的任何陳述或保證或對於**狀況**的任何形式的責任保證。
- 在本目錄條目或**狀況**報告中提及**狀況**不同等同於對**狀況**的完整描述。圖片可能不會清晰顯示出**拍賣品**的色彩和明暗度在印刷品或屏幕上看起來可能會與實體檢查時的情況不同。**狀況**報告可協助您評估**拍賣品**的**狀況**。為方便買方，**狀況**報告為免費提供，僅作為指引。**狀況**報告提供了我們的意見，但是可能未指出所有的缺陷、內在瑕疵、修復、更改及改造，因為我們的僱員不是專業修復或維護人員。出於這個原因，我們不能替代您親自檢查**拍賣品**或您自己專人的專業意見。買方有責任確保自己已經要求提供、收悉及考慮了任何**狀況**報告。

4. 拍賣之前檢查**拍賣品**

- 如果您計劃競投一件**拍賣品**，應親自或通過具有專業知識之代表檢視，以確保您接受**拍賣品**描述之**狀況**。我們建議您從專業修復人員或其他專業顧問那裏索取意見。
- 拍賣之前的檢視免費向公眾開放。在拍賣之前的檢視或通過預約，我們的專家可在場回答問題。

5. 估價

估價是基於**拍賣品**的**狀況**、稀有程度、質量、**來源**及類似物品的近期市場決定。**估價**可能會改變。您或任何其他人任何情況下都不能依據**估價**，將其作為**拍賣品**的實際售價的預測或保證。**估價**不包括**買方**酬金或任何適用的稅費。

6. 撤回

佳士得有權單方面決定在**拍賣品**拍賣過程中或拍賣之前的任何時間將**拍賣品**撤回。佳士得無須就任何撤回決定向您承擔責任。

7. 珠寶

- 所有寶石(如紅寶石、藍寶石及綠寶石)可能經過處理以改良外觀，包括加熱及上油等方法。這些方法都被國際珠寶行業認可，但是經處理的寶石的硬度可能會降低及/或在日後需要特殊的保養。
- 所有類型的寶石均可經過某些改良處理。如果某件**拍賣品**沒有報告，您可以在拍賣日之前至少提前三周向我們要求寶石鑒定報告。報告的費用由您支付。
- 我們不會為每件拍賣的寶石索取**鑒定報告**。若我們有從國際認可的寶石鑒定實驗室取得**鑒定報告**，我們會在目錄中提及。從美國寶石鑒定實驗室發出的**鑒定報告**會描述對寶石的改良或處理。歐洲寶石鑒定實驗室的報告僅在我們要索取的時候，才會提及對寶石的改良及處理，但是該報告會確認該寶石沒有被改良或處理。因實驗室使用方法和技術的差異，對某寶石是否處理過、處理的程度或處理是否為永久性，都可能持不同意見。寶石鑒定實驗室僅對報告作出日之前實驗室所知悉的改良及處理進行報告。

- 對於珠寶銷售來說，**估價**是以寶石鑒定報告中的信息為基礎。如果沒有報告，就會認為寶石可能已經被處理或提升過。

8. 鐘錶

- 幾乎所有的鐘錶在使用期內都會被修理過，可能都含有非原裝零件。我們不能保證任何鐘錶的任何個別零件都是原裝。被陳述為“關聯”字樣的錶帶不是原裝錶的部分，可能不是**真品**。拍賣的鐘錶可能跟隨帶有鐘錶、鐘錶或鐘錶出售。
 - 收藏家等級的錶經常有非常精細複雜的機械構造，可能需要一般保養服務、更換電池或進一步的修理工作，而這些都由買方負責。我們不保證每一隻錶都是在良好運作狀態。除非目錄中有提及，我們不提供證書。
 - 大多數的腕錶都被打開過查看機芯的型號及質量。因為這個原因，帶有防水錶殼的腕錶可能不能防水，在使用之前我們建議您讓專業鐘錶師先檢驗。
- 手錶及錶帶的拍賣及運送方面的重要信息，請見第 H2(g) 段。

B. 登記報投

1. 新競投人

- 如果您這是您第一次在佳士得競投，或者您曾參與我們的拍賣，但在過去兩年內未曾從任何佳士得拍賣場成功競投過任何東西，您必須在拍賣之前至少 48 小時登記，以給我們足夠的時間來處理及批准您的登記。我們有權單方面不允許您登記成為競投人。您應提供以下資料：
 - 個人客戶：帶有照片的身份證明(駕照執照、國民身份證或護照)，如身份信息文件上没有顯示，您當前的住址證明(如：當前的公共事業費帳單或銀行對賬單)。
 - 公司客戶：顯示名稱及注册地址的公司註冊證明或類似文件，以及董事和受益股東的文件證明。
 - 信託、合夥、離業公司及其它業務結構，請提前聯繫我們商談要求。
- 我們可能要求您向我們提供財務證明及/或押金作為許可您競投的條件。如需幫助，請聯繫我們的客戶服務部：+852 2760 1766。

2. 再次參與競投的客人

我們可選擇要求您提供以上 B1(a) 段所提及的現時身份證明、財務證明及/或押金作為許可您競投的條件。如果您過去兩年內沒有從我們的拍賣會成功投得**拍賣品**，或者您本次進出金額高於過往，請聯繫我們的投標部：+852 2978 9910 或電郵至 bidsasia@christies.com。

3. 如果您未能提供正確的文件

如果您認為，您未能滿足我們對競投者身份及登記手續的要求，包括但不限於完成及滿足本公司可能要求進行的所有反洗黑錢和/或反恐衛生義務證書，我們可能會不允許您登記競投。如果您成功投得**拍賣品**，我們可能撤銷您與賣方之間的買賣合約。

4. 代表他人競投

- 作為授權競投人**：如果您代表他人競投，在競投前，委託人需要完成以上的登記手續及提供已簽署的授權書，授權您代表其競投。
- 作為隱名委託人的代理人**：如果您以代理人身份為隱名委託人(最終的買方)進行競投，您同意承擔**支付購買款項**和所有其他應付款項的個人責任。並且，您保證：
 - 您已經根據所有適用的反洗黑錢及制裁法律對**拍賣品**的最終的買方進行必要的客戶盡職調查，同意我們依賴該盡職調查。並且，您將在不少於 5 年的期間妥善保存證明盡職調查的文件和記錄。
 - 您在收到我們書面要求後可以將證明盡職調查的文件和記錄立即提供給獨立第三方審計人員即時查閱。我們不會向任何第三方披露上述文件和記錄，除非(1) 它已經在公共領域存在；(2) 根據法律要求須被披露；(3) 符合反洗黑錢法律規定。
 - 您和最終的買方之間的安排不是為了便於任何涉稅犯罪。

除非非競投人和佳士得在拍賣開始前書面同意競投人僅作為佳士得認可並指定的第三方的代理參與競投並且佳士得只向該指定第三方收取付款，競投人同意繳付**購買款項**和所有其他應付款項個人法律責任。

5. 親自出席競投

如果您希望在拍賣現場競投，必須在拍賣舉行前至少 30 分鐘辦理登記手續，並索取競投號碼牌。如需協助，請聯繫客戶服務部：+852 2760 1766。

6. 競投服務

下述的競投服務是為方便客戶而設，如果在提供該服務出現任何錯誤(人為或其它)，遺漏或故障，佳士得均不負上任何責任。

(A) 電話競投

您必須在拍賣開始前至少 24 小時辦理申請電話競投。佳士得只會在能夠安排人員協助電話競投的情況下接受電話競投。估價低於港幣 30,000 元之**拍賣品**將不接受電話競投。若需要以英語外的其他語言進行競投，須提前在拍賣之前預先安排。電話競投將可被錄音。以電話競投即代表您同意其對話被錄音。您同意電話競投受業務規定所限制。

(B) 在 Christie's LIVE™ 網絡競投

在某些拍賣會，我們會接受網絡競投。請登入 www.christies.com/live/bidding，點擊“現場競投”圖標，瞭解如何從電腦端體驗及觀看拍賣及參與競投。網絡競投受業務規定及 Christie's Live™ 使用條款的管限，詳情請見 www.christies.com 網站。

(C) 書面競投

您可於本目錄，任何佳士得辦公室或通過 www.christies.com 選擇拍賣並查看**拍賣品**取得書面競投資格。您必須在拍賣開始前至少 24 小時提交已填妥的書面競投表格。投標必須是以拍賣會當地的貨幣為單位。拍賣官將在參考**底價**後，合理地履行書面競投請求以可能的最低價價行使書面競投。如果您以書面投一件沒有**底價**的**拍賣品**，而且沒有其他更高叫價，我們為您以**最低估價**的 50% 進行競投；或如果您書面的叫價比上述更低，則以您的書面的價格進行競投。如果您傳收到多個競投價格相等的書面競投，而在拍賣時此等競投價格乃該**拍賣品**之最高出價，則該**拍賣品**售給最先送達其書面競投書給本公司之競投人。

3. 拍賣之時

1. 進入拍賣現場

我們不允許任何人士進入拍賣場地，參與拍賣，亦可拒絕接受任何競投。

2. 底價

除非另外列明，所有**拍賣品**均有**底價**。不定有**底價**的**拍賣品**，在**拍賣品**號碼旁選用-標記，**底價**不會高於**拍賣品**的**低價估價**。

3. 拍賣官之酌情權

拍賣官可以酌情選擇：

- 拒絕接受任何競投；
- 以具決定方式將競投提前或拖後，或改變**拍賣品**的順序；
- 撤回任何**拍賣品**；
- 將任何**拍賣品**分開拍賣或將兩件或多件**拍賣品**合併拍賣；
- 重開或繼續競投，即變更下號；
- 如果有出錯或爭議，無論是在拍賣時或拍賣後，選擇繼續拍賣、決定達成成功競投人、取消**拍賣品**的拍賣或將**拍賣品**重新拍賣或出售。在拍賣之時或後對競投有任何爭議，拍賣官有最終決定權。

4. 競投

拍賣官接受以下競投：

- 拍賣會場參與競投的競投人；
- 從**電話競投人**，通過 Christie's Live™ (如第 B6 部分所示) 透過網絡競投的競投人；
- 拍賣之前提交佳士得的書面競投(也稱為不在場競投或委託競投)。

5. 代表買方競投

拍賣官可選擇代表買方競投的方式連續競投或以回應其他競投者的投標而競投的方式，直至達到**底價**以下。拍賣官不會特別指明此乃代表買方的競投。拍賣官不會代表買方作出等於或高於**底價**之出價。就不設**底價**的**拍賣品**，拍賣官通常會以**低價估價**的 50% 開始投標。如果在此價位沒有人競投，拍賣官可以自行將投標價格下降繼續拍賣，直至有人競投，然後從該價位向上拍賣**拍賣品**。如果無人競投投該**拍賣品**，拍賣官可視該**拍賣品**為**拍賣品**。

6. 競投價遞增幅度

競投通常會從低於**低價估價**開始，然後逐步增加(競投價遞增幅度)。拍賣官會自行決定競投開始價位及遞增幅度。本目錄內的書面競投表格上顯示的一般遞增幅度，僅供閣下參考。

7. 貨幣兌換

拍賣會的顯示板 (Christie's Live™) 可能會以港幣及其它主要貨幣來展示該投標。任何兌換率僅作指引，佳士得並不受其約束。對於在提供該服務出現的任何錯誤 (人為或其它)，遺漏或故障，佳士得並不負責。

8. 成功競投

除非拍賣官決定使用以上 C3 段中的酌權，拍賣官下壓即表示對最終競投價之接受。這代表賣方和成功競投人之間的買賣合約之訂立。我們僅向已登記的成功競投人開具發票。拍賣後我們會以郵寄及/或電子郵件方式發送發票，但我們並不負責通知閣下競投是否成功。如果您以書面競投，拍賣後您應儘快以電話聯繫我們或親臨本公司查詢競投結果，以避免產生不必要的倉儲費用。

9. 競投地法律

當您在我們的拍賣中競投時，您同意您會嚴格遵守所有在拍賣時生效並適用於相關拍賣場所的當地法律及法規。

D. 買方佣金及稅款

1. 買方佣金

成功競投人除支付**成交價**外，亦同意支付本公司以該**拍賣品成交價**計算的**買方佣金**。佣金率按每件**拍賣品成交價**至港幣1,200,000元之25%、加逾港幣1,200,000元以上至港幣20,000,000元部分之20%、加逾港幣20,000,000元以上之12%計算。

名酒的**買方佣金**是按每件**拍賣品成交價**之22.5%。

2. 稅費

成功競投者將負責所有適用**拍賣品稅費**，包括增值稅、銷售或補償使用稅費或者所有基於**成交價**和**買方佣金**而產生的稅費。賣方有責任查明並支付所有應付稅費。在任何情況下香港法律先方適用。

E. 保證

1. 買方保證

對於每件**拍賣品**，買方保證其：

- 為**拍賣品**的所有人，或**拍賣品**的共同人之一並獲得其他共有人的許可；或者，如果賣方不是**拍賣品**的所有人或其他共有人之一，其已獲得所有人的授權出售**拍賣品**或其任法律上有權處置；
- 有權利將**拍賣品**的所有權轉讓給買方，且該權利不負擔任何限制或任何其他人的索賠。

如果以上任何**保證**不確實，買方不必支付超過您已向我們支付的**購買款項** (詳見以下第 F1(a) 段定義) 的金額。賣方不會就關連利潤上或經營的損失、預期存款、商標喪失或利息的損失、成本、賠償金、**其他賠償**或支出承擔責任。買方不就此任何**拍賣品**提供任何以上列舉之外的**保證**；只要法律許可，所有賣方對您作出的**保證**及法律要求加入本協議的所有其它賣方責任均被免除。

2. 真品保證

在不抵觸以下條款的情況下，本公司保證我們**拍賣品**都是**真品** (我們的**“真品保證”**)。如果在拍賣日的五年內，您使我們滿意您的**拍賣品**不是**真品**，或在符合以下條款規定之下，我們將把您支付的**購買款項**退還給您。業務規定的詞匯表裏對**“真品”**一詞做出解釋。**真品保證**條款如下：

- 我們在拍賣日後的5年內提供**真品保證**。此期限過後，我們不再提供**真品保證**。
- 我們只會對本目錄描述第一行 (“**標題**”) 以**大贈字體**注明資料作出**真品保證**。除了**標題**中顯示的資料，我們不對任何**標題**以外的資料 (包括**標題**以外的大贈字體註明) 作出任何**保證**。
- 真品保證**不適用於**保留標題**或有**保留**的部分**標題**。**有保留**是指受限於**拍賣目錄**描述內的解釋，或者**標題**中有“重要通告及目錄編列方法之說明”內有**保留標題**的某些字眼。例如：**標題**中對“認為是...之作品”的使用指佳士得認為**拍賣品**可能是某位藝術家的作品，但是佳士得不保證該作品一定是該藝術家的作品。在競投前，請閱覽“**保留標題**”列表及**拍賣品**的**目錄描述**。
- 真品保證**適用於於**拍賣會通告**訂下的**標題**。
- 真品保證**不適用於在拍賣之後，學術發展導致被普遍接受的學者或專家意見有所改變。此保證亦不適用於在拍賣日時，**標題**字含被普遍接受的學者或專家的意見，或**標題**指出意見衝突的地步。
- 如果**拍賣品**只有通過科學鑒定方法才能鑒定出不是**真品**，而我們在出版目錄之日，該科學方法還存在或未被普遍認可，或價格太貴或不實際，或者可能損壞**拍賣品**，則**真品保證**不適用。
- 真品保證**僅適用於**拍賣品**在拍賣時由佳士得發出的發票之原本賣方，且僅在原本賣方在拍賣日與申索之日持續擁有該**拍賣品**才適用。保證中的利益不可以轉讓。

(h) 要申索**真品保證**下的權利，您必須：

- 在拍賣日後5年內，向我們提供書面的申索通知並提供詳情，包括完整的佐證證據；
- 佳士得有權要求您提供佳士得及您均事先同意的在此**拍賣品**領域被認可的兩位專家的書面意見，確認該**拍賣品**不是**真品**。如果我們有任何疑問，我們保留自己支付費用獲取更多意見的權利；及
- 自費交回與拍賣時狀況相同的**拍賣品**給佳士得**拍賣場**。

(i) 您在**本真品保證**下唯一的權利就是取消該項**拍賣**及取回已付的**購買款項**。在任何情況下我們不須支付您超過您已向我們支付的**購買款項**的金額，同時我們也無須對任何利潤或經營損失、商標或價值喪失、預期存款或利息、成本、賠償金或**其他賠償**或支出承擔責任。

(j) **書畫**。如果**拍賣品**為**書畫**，我們提供額外自拍賣日起為期14天的**保證**，如經校對後，我們將您的文本或圖樣存有瑕疵，在以下條款的規限下，我們將退回已付的**購買款項**：

- 此類**保證**不適用於：
 - 缺少空白頁、扉頁、保護頁、廣告、及書籍鑲邊的破損、污漬、邊緣磨損或其它不影響文本及圖樣完整性的瑕疵；
 - 繡圖、簽名、書信或手稿；帶有簽名的照片、音樂唱片、地圖冊、地圖或期刊；
 - 沒有標題的書籍；
 - 沒有標明**估價**的已出售**拍賣品**；
 - 目錄中表明售出後不可退貨的書籍；
 - 狀況報告中或拍賣時公告的瑕疵。
- 要根據本條規定申索權利，您必須在拍賣後的14天內就有關瑕疵提交書面通知，並交回與拍賣時狀況相同的**拍賣品**給當時進行拍賣的佳士得**拍賣場**。

(k) 東南亞現代及當代藝術以及中國書畫

真品保證並不適用於此類**拍賣品**。目前學術界不容許對此類別作出確實之說明，但佳士得無須取消被證實為偽品之東南亞現代及當代藝術以及中國書畫**拍賣品**之交易。已付之**購買款項**則根據佳士得**真品保證**的條款退還予原本賣方，但買方必須在拍賣日起12個月內以書面通知本公司有關**拍賣品**為偽品並能按以上 E2(ii)(h) 的規定提供令佳士得滿意的證據，證實該**拍賣品**為偽品，及須按照以上 E2(i)(ii) 規定交回**拍賣品**給我們。E2(b), (c), (d), (e), (f), (g) 及 (i) 適用於此類別之申索。

(l) 有關名酒及烈酒**保證**

(a) 佳士得所接受的責任所限，賣方、佳士得、其員工或代理人均無須對有關任何貨批的任何聲明的出處、來源、日期、年份、屬性、真實性或出處之正確性負責。賣方對任何其他錯誤說明及**拍賣品**的缺陷或損毀亦無須負責。而賣方、佳士得、其員工或代理人均不對對任何**拍賣品**作出**保證**，並在排除除任何明示或默示的狀況或**保證**。

(b) 如果，(1) 在拍賣日期的二十一日前，佳士得收到買方對任何**拍賣品**的書面通知，在競投當日買方觀察到**拍賣品**的水位不足或有自然耗損或目錄中任何意見的聲明並未有良好事實基礎，(2) 在收到有關通知的十四日內，佳士得擁有之**拍賣品**與競投當日的狀況相同，及(3) 在期後的一段合理時間內，買方令佳士得確信有關**拍賣品**如上述及方的書面通知的情況，而賣方能夠在無任何保留置權及妨礙下轉讓有關**拍賣品**的擁有權，佳士得將會撤銷賣方與買方退還賣方支付有關**拍賣品**的所有款項。如出現以下情況，買方將無本條款所載之權利：

- 該損毀已在目錄中提及；或
- 在競投當日目錄的說明已符合學者或專家作出的一般被接納的意見，或該說明已公正地顯示有關意見會有分歧；或
- 不可憑在目錄印行前仍通常不被採用的科學程序之方法，或採用在競投當日是不合理地昂貴或不可行的程序之方法，或可能損毀**拍賣品**的方法，才可查**拍賣品**競投當時的情況如上述及方的書面通知的情況。(請參閱耗損及酒塞的說明)；

(c) 買方不可根據此條件索償高於該**拍賣品**所支付的金額，也不得就任何其直接或間接遭受之損失、附帶損失或損壞作出索償；

(d) 此項**保證**之利益不得轉讓，且**拍賣品**出售時佳士得向其發原有提貨單之買方全權及絕對擁有，買方於出售後一直維持擁有權，買方的擁有權從來未曾中斷或被用作抵押或擔保用途。

F. 付款

1. 付款方式

- 拍賣後，您必須立即支付以下**購買款項**：
 - 成交價；和
 - 買方佣金；和
 - 任何關稅、有關貨物、銷售、使用、補償或服務稅項。所有款項須於拍賣後7個日曆天內悉數付清 (“**到期付款日**)”。

(b) 我們只接受受託競投人付款。發票一旦開具，發票上買方的姓名不能更換，我們亦不能以不同姓名重新開具發票。即使您欲將**拍賣品**出口且需要出口許可證，您也必須立即支付以上款項。

(c) 在香港下列式購買的**拍賣品**，您必須按照發票上顯示的貨幣以下列方式支付：

- 電匯至：
香港上海匯豐銀行總行
香港中環皇后大道中1號
銀行編號：004
賬號：062-305438-001
賬名：Christie's Hong Kong Limited
匯款銀行代號：HSBKHKHHKX
- 信用卡

在符合我們的規定下，我們接受各種主要信用卡付款。本公司每次**拍賣**接受受總款不超過港幣1,000,000元之現場信用卡付款，但有關係款及限制適用。以中國銀聯支付方式沒有金額限制。如每次以“持卡人不在場”(CNP) 的方式支付，本公司每次**拍賣**接受受總款不超過港幣500,000元之付款。您必須填妥 CNP 授權表格，該表格可向我們索取，請將已填妥之 CNP 授權表格以傳真 (+852 2973 0111) 或以郵寄方式發送到以下 (d) 段的地址。CNP 付款不適用於所有佳的**拍賣場**，並受某些限制。適用於信用卡付款的條款和限制可從佳士得的售後服務部獲取，詳情列於以下 (d) 段：

- 現金
本公司每年只接受每位買方總款不超過港幣80,000元之現金付款 (須受有關條件約束)；
- 銀行匯票
抬頭請註明“佳士得香港有限公司” (須受有關條件約束)；
- 支票
抬頭請註明“佳士得香港有限公司”。支票必須於香港銀行兌現並以港幣支付。
- 支付時請註明**拍賣編號**、發票號碼及客戶號碼；以郵寄方式支付必須發送到：佳士得香港有限公司，售後服務部 | 地址：香港中環遮打道18號匯豐大廈22樓)。
- 如要瞭解更多信息，請聯繫售後服務部。電話 +852 2760 1766；傳真：+852 2973 0111。

2. 所有權轉移

只有我們自您收到全額且清償**購買款項**後，您才擁有**拍賣品**及**拍賣品**的所有權，即使本公司已將**拍賣品**交還您。

3. 風險轉移

拍賣品的風險和責任自以下日期起將轉移給您 (以較早者為準)：

- 買方實貨日；
- 自拍賣日起計7日後，如較早，則**拍賣品**根據“香港佳士得名酒倉存及提取及儲存”頁由第三方倉庫保管之日起；除非另行協議。

4. 不付款之補救辦法

- 如未到期**付款日**，您未能全數支付**購買款項**，我們將有權行使以下一項或多項 (及執行我們在 F5 段的權利或以法律賦予我們的其它權利或補救辦法)：
 - 自**到期付款日**起，按照尚欠款項，收取高於香港金融管理局不時公布的三個月銀行同業拆息加7%的利息；
 - 取消交易並按照我們認為合適的條件對**拍賣品**公開重新**拍賣**或私下重新售賣。您必須向我們支付原來您應支付的**購買款項**與再次**拍賣**或售賣之間的差額。您也必須支付必須支付或可能蒙受的一切成本、費用、損失、賠償、法律費用及任何買方佣金之差額；
 - 不進行責任的買方支付賣方應付的**購買款項**金額。您承認佳士得擁有**拍賣品**之所有權利向您提出追討；
 - 您必須承擔尚欠之**購買款項**，我們可取回超出此金額而向您提出法律訴訟程序及在法律許可下向您索回之其他損失、利息、法律費用及其他費用；
 - 將我們或佳士得保留任何公司欠下您之款項 (包括您已付給我們之任何保證金或部分付款) 用以抵銷您未付之款項；
 - 我們將以選擇將您的身份及聯繫方式披露給買方；
 - 在將任何**拍賣品**中，不允許您或您的代表作出競投，或在接受您競投之前向您收取保證金；
 - 在**拍賣品**所處地方之法律許可之下，佳士得就您擁有或由佳士得管有的**拍賣品**或以抵押品並以抵押品與他人身份行使最高程度之權利及補救方法，不論是與典當方式、抵押方式或任何其他形式。您則被視為已授與本公司該等抵押及本公司可保留或轉讓此物品作為買方對本公司及賣方的附屬抵押責任；和
 - 採取我們認為必要或適當的任何行動。

- b) 將您已付的款項，包括保證金及其他部份付款或我們欠您的之款項用以抵銷您欠我們或其他**佳士得集團公司**的款項。
- c) 如果您在**到期付款日**之後支付全部款項，同時，我們選擇接受該付款，我們可以自拍賣後第 35 日起根據 G(c) 段向您收取倉儲和運輸費用。

5. 扣押拍賣品

如果您欠我們或其他**佳士得集團公司**款項，除了以上 F4 段的權利，在法院許可下，我們可以以任何方式使用或處置您欠於我們或其他**佳士得集團公司**的**拍賣品**。只有您在全額支付欠於我們或相關**佳士得集團公司**的全部款項後，您方可領回有關**拍賣品**。我們可選擇將您的**拍賣品**按照我們認為適當的方式出售。我們將用出售**拍賣品**的銷售所得來抵銷您欠我們的任何款項，並支付我們任何剩餘部分。如果銷售所得不足以抵銷，您須支付差額。

G. 提取及倉儲

- (a) 我們要求您在拍賣之後立即提取您購買的**拍賣品**（但請注意，在全數付清所有款項之前，您不可以提取**拍賣品**）。
- (b) 有關提取**拍賣品**之詳情已列明於「香港佳士得各港區提取及儲存」頁。
- (c) 買方若未能於「香港佳士得名酒提取及儲存」頁列明的期限內提取**拍賣品**，除非另有書面約定：
- 我們將從當日起收取倉儲費。
 - 我們可以按我們認為商業上合理且恰當的方式出售**拍賣品**。
 - (iii) 本段的任何內容不限制我們在 F4 段下的權利。

H. 運送

1. 運送

運送或付運包裹與發票一同發送給您。您須自行安排**拍賣品**的運送和付運事宜。我們也可以依照您的要求安排包裝運送及付運事宜，但您須支付有關收費。我們建議您在發件前預先查詢有關收費的估價，尤其是需要專業包裝的大件物品或高價值品。您應要求，我們也應建議處理、包裝、運輸公司或有關專家。

詳情請聯繫**佳士得**後服務部，電話：+852 2760 1766 或發郵件至 postalesia@christies.com。我們會合理處理和包裝、運輸**拍賣品**。若我們就上述目的向您推薦任何其他公司，我們不會承擔有關公司之行為、遺漏或疏忽引致的任何責任。

2. 出口 / 進口

拍賣售出的任何**拍賣品**都可能受**拍賣品**售出國家的出口法律及其他國家的進口法律限制。許多國家要求**拍賣品**出口法律許可聲明及 / 或就**拍賣品**入境要求進口聲明。進口國當地法律可能禁止運送進口某些**拍賣品**或禁止**拍賣品**在進口國出售。

- (a) 在競投前，您應尋求專業意見並確保滿足任何法律或法規對出口或進口**拍賣品**的要求。如果您被拒絕許可證，或申請許可證延誤，您仍須全數支付**拍賣品**的款項。如果您提出請求，在我們能力範圍許可內，我們可以協助您申請所需許可證，但我們會就此服務向您收取費用。我們不保證必能獲得許可證。如欲了解詳情，請聯繫**佳士得**後服務部，電話：+852 2760 1766 或發郵件至 postalesia@christies.com。

(b) 含有受保護動物標本的**拍賣品**

由瀕臨絕種及其他受保護野生動物標本製成或組成（不論百分比）的**拍賣品**在本目錄中註有 [-] 號。這些物品包括但不限於象牙、玳瑁殼、鱷魚皮、犀牛角、鯨骨、某些珊瑚標本及巴西玫瑰木。若您有意將含有野生動物標本的任何**拍賣品**出口至其他國家，您應於競投**拍賣品**之前了解有關海關法律和規定。有些國家完全禁止含有這類動物的物品進口，而其他國家則規定須向出口及入口國家的有關管理機構取得許可證。在有些情況下，**拍賣品**必須附有獨立刊印的物種科學證明和 / 或年期證明，方能裝運，而您須要自行安排上述證明並負責支付有關的費用。如果一件**拍賣品**含有象牙或其他可能和象牙相混淆的野生動物材料（例如猛犸象牙，海象象牙和犀牛角牙）且您計劃將上述**拍賣品**運送到美國，請查看(c)段中之重要信息。如果您無法出口，進口該**拍賣品**或因任何原因**拍賣品**被政府部門查收，我們沒有義務因此取消您的交易並退回您的**購買款項**。您應負責確定並滿足有關含有上述動物**拍賣品**進出口的法律和規例要求。

(c) 美國關於非洲象象牙的進口禁令

美國禁止非洲象象牙進口美國。如果一件**拍賣品**含有象牙或其他可能和象牙相混淆的野生材料（例如猛犸象牙，海象象牙和犀牛角牙），其必須通過受美國漁業和野生動物保護局認可的嚴格科學測試確認該物種非非洲象象牙方可進口美國。如果我們在拍賣前對**拍賣品**已經進行了該嚴格科學測試，我們會在**拍賣品**陳述中清楚表明。我們一經無法確認**拍賣品**的象牙是否來自非洲象。您凡購買有關**拍賣品**並計畫將有關**拍賣品**進口美國，必須承擔風險並

負責支付任何科學測試或其他報告的費用。有關測試並無定論或確定物種非非洲象象牙，不被視為取消拍賣和退回**購買款項**的依據。

(d) 源自伊朗的**拍賣品**

一些國家禁止或限制購買和 / 或進口源自伊朗的“傳統工藝作品”（身份不明確的藝術家作品及 / 或功能性作品。例如：地毯、碗、大口水壺、瓷磚和裝飾盒）。美國禁止進口以上物品亦禁止美國民眾（不論所在處）購買以上物品。有些國家，例如加拿大則允許在某特定情況下可以進口上述物品。為方便買方，佳士得在源自伊朗（波斯）的**拍賣品**下方特別註明，如您受以上制裁或貿易禁運限制，您須確保您不會競投或進口有關**拍賣品**，違反有關適用條例。

(e) 黃金

含量低於 18k 的黃金並不是在所有國家均被視為“黃金”，並可能被拒絕入口。

(f) 鐘錶

- (i) 本目錄內有些鐘錶的照片顯示手錶配有滿倉及受保護動物（如短吻鱷或鱷魚）的物料所製成的錶帶。這些**拍賣品**在本目錄內的**拍賣品**編號旁，以符號顯示。這些錶帶只用來展示**拍賣品**並不作銷售用途。在運送手錶到拍賣地以外的地點前，佳士得會把上述錶帶拆除並予以保存。買方若在拍賣後一年內親身到貨物所在地佳士得提取，佳士得可酌量免費提供錶帶給買方，但含有滿倉及受保護動物標本的錶帶除外。
- H2 段中的標記是佳士得為了方便閣下在有關**拍賣品**附近的附加標記時如有任何錯誤或遺漏，佳士得恕不承擔任何責任。

I. 佳士得之法律責任

- (a) 除了**真品保證**，佳士得、佳士得代理人或僱員，對任何**拍賣品**作任何陳述，或資料的提供，均不作出任何**保證**。在法律容許的最大限度下，所有由律師附加的保證及其他條款，均被排除在本協議外。在 E1 段中的賣方保證是由賣方提供的保證，我們對這些**保證**不負有任何責任。

- (b) (i) 除非我們以欺詐手段作出有欺詐成份的失實陳述或在**本業務規定**中有明確說明，我們不會因任何原因對您負有任何責任（無論是因違反本協議，購買**拍賣品**或與競投相關的任何其他事項）；或 (ii) 賣方、本公司、本公司之僱員或代理人均無就任何**拍賣品**的可商售品質，是否適合其特定用途、描述、尺寸、質量、狀況、作品歸屬、真實性、稀有程度、重要性、媒介、來源、展覽歷史、文獻或歷史的關聯等作出任何陳述、保證或擔保或承擔任何責任。除非非當地的法律強制要求，任何種類的任何**保證**，均被本條排除在外。

- (c) 請注意佳士得所提供的書面競投及電話競投服務、Christie's Live™、狀況報告、貨幣兌換顯示板及拍賣室錄像影像為**免費**服務。如有任何錯誤（人為或任何其他原因）、遺漏或故障或延誤，未能提供、暫停或終止，本公司不負任何責任。

- (d) 就**拍賣品**購買的事實，我們僅對賣方負有法律責任。
- (e) 如果儘管有 (a) 至 (d) 或 E(1) 段的規定，我們因某些原因須對您負上法律責任，我們不須支持超過您已支付的**購買款項**。佳士得不須就任何利潤或經營支出、商機喪失或價值、預期存款或利息、費用、賠償或支出等因您負上任何責任。

J. 其他條款

1. 我們的撤銷權

除了本協議中的其他撤銷權利，如果我們合理地認為完成交易可能是違法行為或該銷售會令我們或賣方向任何他人負上法律責任或損壞我們的名譽，我們可取消該**拍賣品**的拍賣。

2. 錄像

我們可以錄影及記錄**拍賣品**過程。除非按法律要求，我們會對個人信息加以保密。該資料可能用於提供其他**佳士得集團公司**和市場夥伴以作客戶分析或以便我們向賣方提供合適的服務。若您不想被錄影，您可透過電話或書面競投或在 Christie's LIVE™ 競投。除非另有書面約定，您不能在拍賣現場錄像或錄影。

3. 版權

所有由佳士得或為佳士得與**拍賣品**有關之製作之一切圖冊、插圖與書面資料（除有特別注明外，包括我們的目錄的內容）之版權均屬於佳士得所有。沒有我們的書面許可不得使用以上版權作品。我們沒有保證您就取得的**拍賣品**會取得任何版權或其他複製的權利。

4. 效力

如本協議的任何部份因任何法院認定為無效、不合法或無法執行，則該部分應被視為刪除，其它部分不受影響。

5. 轉讓您的權利及責任

除非我們給予書面許可，否則您不得就您在本協議下的權利或責任設立任何抵押，亦不得轉讓您的權利和責任。本協議對您的繼任人、遺產及任何承繼閣下責任的人具有約束力。

6. 翻譯

如果您提供了本協議的翻譯件，我們將會使用英文版用於解決本協議下產生的任何問題以及爭議。

7. 個人信息

您同意我們將持有並處理您的個人數據或信息，並將其交給其他**佳士得集團公司**用於我們的私隱政策所描述的目的，或與其相符的目的。您可以在 www.christies.com 上找到本公司私隱政策。

8. 棄權

未能或延遲行使本業務規定下的權利或補償不應被視為免除該權利或補償，也不應阻止或限制對該權利或補償或其他權利或補償的行使。棄權或部分行使該權利或補償不應阻止或限制對其它權利或補償的行使。

9. 法律及管轄權

各方的權利及義務，就有關本業務規定，拍賣的行為及任何與上述條文的事項，均受香港法律管轄及根據香港法律解釋。在拍賣競投時，無論是親自出席或由代理人出席競投，書面、電話及其他方法競投，買方即被視為接受本業務規定，及為佳士得之利益而言，接受香港法院之排他性管轄權，並同時接納佳士得亦有權在任何其他司法管轄區提出索償，以追討買方拖欠的任何款項。

10. www.christies.com 的報告

售出的**拍賣品**的所有資料，包括目錄描述及價款都可在 www.christies.com 上查詢。銷售總額成交價加上買方酬金，其不反映本港、財務費用或買方或貨品信貸申請情況。我們不能按要求將這些資料從 www.christies.com 網站上刪除。

K. 詞彙表

以下所述的真實作品，而不是複製品或仿品：

- 拍賣品**在標題被描述為某位藝術家、作者或製作者的作品，則為該藝術家、作者或製造者的作品；
- 拍賣品**在標題被描述為是某時期或流派創作的作品，則該時期或流派的作品；
- 拍賣品**在標題被描述為某來源，則為該來源的作品；
- 以寶石為例，如**拍賣品**在標題被描述為由某種材料製成，則該作品是由該材料製成。

真品保證：我們在本協議 E 段所述述為**拍賣品**提供的保證。

目錄描述：除了**成交價**，買方支付給我們的費用。

買方酬金：拍賣目錄內對**拍賣品**的陳述（包括於拍賣場通過對有關陳述作出的任何更改）。

佳士得集團：Christie's International Plc、其子公司及集團的其它公司。

拍賣品：拍賣品的物理狀況。

到期付款日：如第 F(a) 段所列出的意思。

估價：目錄中或拍賣場通告中列明的我們認為**拍賣品**可能出售的價格範圍。低端估價指該範圍的最低值；高端估價指該範圍的最高值。中間估價為兩者的中間點。

成交價：拍賣官接受的**拍賣品**最高競投價。

標題：如 E2 段所列出的意思。

拍賣品：供拍賣的一件**拍賣品**（或作為一組拍賣的兩件或更多的物件）；

其他賠償：任何特殊、連帶、附帶或間接的賠償或任何符合當地法律規定的“特殊”、“附帶”或“連帶”賠償。

購買款項：如第 F(1) 段的意思。

來源：**拍賣品**的所有權歷史。

有保留：如 E2 段中的意思；**有保留**標題則指目錄中“重要通知和目錄編制說明”頁中的“有保留標題”的意思。

底價：**拍賣品**不會以低於此底價出售。

拍賣場通告：張貼於拍賣場內的**拍賣品**旁或 www.christies.com 的書面通知（上述通知內容會另行通知以電話或書面競投的客戶），或拍賣官舉行前或拍賣官**拍賣品**前拍賣官宣布的公告。

大寫字體：指包含所有的大寫字母。

保證：陳述人或聲明人保證其所陳述或聲明的事實為正確。

SYMBOLS USED IN THIS CATALOGUE

The meaning of words coloured in **bold** in this section can be found at the end of the section of the catalogue headed 'Conditions of Sale - Buying at Christie's'

○ Christie's has a direct financial interest in the **lot**. See Important Notices and Explanation of Cataloguing Practice.

△ Owned by Christie's or another **Christie's Group** company in whole or in part. See Important Notices and Explanation of Cataloguing Practice.

◆ Christie's has a direct financial interest in the **lot** and has funded all or part of our interest with the help of someone else. See Important Notices and Explanation of Cataloguing Practice.

· **Lot** offered without **reserve** which will be sold to the highest bidder regardless of the pre-sale estimate in the catalogue.

- **Lot** incorporates material from endangered species which could result in export restrictions. See Section H2(b) of the Conditions of Sale - Buying at Christie's.

Please note that **lots** are marked as a convenience to you and we shall not be liable for any errors in, or failure to, mark a **lot**.

本目錄中使用的各類標識

本部份粗體字體詞語的涵義載於本目錄中題為“業務規定·買方須知”一章的最後一頁。

○ 佳士得對該**拍賣品**擁有直接經濟利益。請參閱重要通知及目錄編列方法之說明。

△ 全部或部分由佳士得或其他**佳士得集團**公司持有。請參閱重要通知及目錄編列方法之說明。

◆ 佳士得對該**拍賣品**擁有直接經濟利益，佳士得的全部或部分利益通過第三方融資。請參閱重要通知及目錄編列方法之說明。

· 不設**底價**的**拍賣品**，不論其在本目錄中的售前**估價**，該**拍賣品**將售賣給出價最高的競投人。

- **拍賣品**含有瀕危物種的材料，可能受出口限制。請參閱業務規定·買方須知第 H2(b) 段。

請注意對藏品的標記僅為您提供方便，本公司不承擔任何因標示錯誤或遺漏標記的責任。

IMPORTANT NOTICES AND EXPLANATION OF CATALOGUING PRACTICE

IMPORTANT NOTICES

CHRISTIE'S INTEREST IN PROPERTY CONSIGNED FOR AUCTION

△: Property Owned in part or in full by Christie's

From time to time, Christie's may offer a lot which it owns in whole or in part. Such property is identified in the catalogue with the symbol △ next to its lot number.

○ Minimum Price Guarantees:

On occasion, Christie's has a direct financial interest in the outcome of the sale of certain lots consigned for sale. This will usually be where it has guaranteed to the Seller that whatever the outcome of the auction, the Seller will receive a minimum sale price for the work. This is known as a minimum price guarantee. Where Christie's holds such financial interest we identify such lots with the symbol ○ next to the lot number.

○◆ Third Party Guarantees/Irrevocable bids

Where Christie's has provided a Minimum Price Guarantee it is at risk of making a loss, which can be significant, if the lot fails to sell. Christie's therefore sometimes chooses to share that risk with a third party. In such cases the third party agrees prior to the auction to place an irrevocable written bid on the lot. The third party is therefore committed to bidding on the lot and, even if there are no other bids, buying the lot at the level of the written bid unless there are any higher bids. In doing so, the third party takes on all or part of the risk of the lot not being sold. If the lot is not sold, the third party may incur a loss. Lots which are subject to a third party guarantee arrangement are identified in the catalogue with the symbol ○◆.

The third party will be remunerated in exchange for accepting this risk based on a fee on the final hammer price in the event that the third party is not the successful bidder. The third party may also bid for the lot above the written bid and where it does so, and is the successful bidder, it will not receive a fee.

Third party guarantors are required by us to disclose to anyone they are advising their financial interest in any lots they are guaranteeing. However, for the avoidance of any doubt, if you are advised by or bidding through an agent on a lot identified as being subject to a third party guarantee you should always ask your agent to confirm whether or not he or she has a financial interest in relation to the lot.

Other Arrangements

Christie's may enter into other arrangements not involving bids. These include arrangements where Christie's has given the Seller an Advance on the proceeds of sale of the lot or where Christie's has shared the risk of a guarantee with a partner without the partner being required to place an irrevocable written bid or otherwise participating in the bidding on the lot. Because such arrangements are unrelated to the bidding process they are not marked with a symbol in the catalogue.

Bidding by parties with an interest

In any case where a party has a financial interest in a lot and intends to bid on it we will make a saleroom announcement to ensure that all bidders are aware of this. Such financial interests can include where beneficiaries of an Estate have reserved the right to bid on a lot consigned by the Estate or where a partner

in a risk-sharing arrangement has reserved the right to bid on a lot and/or notified us of their intention to bid.

Please see <http://www.christies.com/financial-interest/> for a more detailed explanation of minimum price guarantees and third party financing arrangements.

Where Christie's has an ownership or financial interest in every lot in the catalogue, Christie's will not designate each lot with a symbol, but will state its interest in the front of the catalogue.

FOR PICTURES, DRAWINGS, PRINTS AND MINIATURES, SCULPTURES, INSTALLATION, VIDEO, CALLIGRAPHY AND PAINTED CERAMIC

Terms used in this catalogue have the meanings ascribed to them below. Please note that all statements in this catalogue as to authorship are made subject to the provisions of the Conditions of Sale and authenticity warranty. Buyers are advised to inspect the property themselves. Written condition reports are usually available on request.

QUALIFIED HEADINGS

In Christie's opinion a work by the artist.

**Attributed to ...

In Christie's qualified opinion probably a work by the artist in whole or in part.

**Studio of .../ "Workshop of ..."

In Christie's qualified opinion a work executed in the studio or workshop of the artist, possibly under his supervision.

**Circle of ...

In Christie's qualified opinion a work of the period of the artist and showing his influence.

**Follower of ...

In Christie's qualified opinion a work executed in the artist's style but not necessarily by a pupil.

**Manner of ...

In Christie's qualified opinion a work executed in the artist's style but of a later date.

**After ...

In Christie's qualified opinion a copy (of any date) of a work of the artist.

**Signed ..."/"Dated ..."/

"Inscribed ..."

In Christie's qualified opinion the work has been signed/dated/inscribed by the artist.

**With signature ..."/"With date ..."/

"With inscription ..."

In Christie's qualified opinion the signature/ date/inscription appears to be by a hand other than that of the artist.

The date given for Old Master, Modern and Contemporary Prints is the date (or approximate date when prefixed with 'circa') on which the matrix was worked and not necessarily the date when the impression was printed or published.

*This term and its definition in this Explanation of Cataloguing Practice are a qualified statement as to authorship. While the use of this term is based upon careful study and represents the opinion of specialists, Christie's and the consignor assume no risk, liability and responsibility for the authenticity of authorship of any lot in this catalogue described by this term, and the Authenticity Warranty shall not be available with respect to lots described using this term.

OPTIONS TO BUY PARCELS

A parcel consists of several lots of the same wine of identical lot size, bottle size and description. Bidding will start on the first lot of the parcel and the successful buyer of that lot is entitled to take some or all of the remaining lots in the parcel at the same hammer price. If the buyer of the first lot does not take further lots, the remaining lots of the parcel will be offered in a similar fashion. We recommend that a bid on a parcel lot be placed on the first lot of the parcel. If the bid is superseded, Christie's will automatically move your bid to the next identical lot and so on. In all instances, such bids will be handled at the auctioneer's discretion.

CLASSIFICATIONS

Bordeaux Classifications in the text are for identification purposes only and are based on the official 1855 classification of the Médoc and other standard sources. All wines are Château-bottled unless stated otherwise.

ULLAGES AND CORKS OF OLD WINES

Wines are described in this catalogue as correctly as can be ascertained at time of going to press, but buyers of old wines must make appropriate allowances for natural variations of ullages, conditions of cases, labels, corks and wine. No returns will be accepted.

ULLAGE

The amount by which the level of wine is short of being full: these levels may vary according to age of the wines and, as far as can be ascertained by inspection prior to the sale, are described in the catalogue. A chart explaining level and ullage descriptions and interpretations, together with a visual presentation, appears in this catalogue. We hope you will find this helpful.

重要通知及目錄編列方法之說明

重要通告

佳士得在受委託拍賣品中的權益

△: 部分或全部歸佳士得擁有的拍賣品

佳士得可能會不時提供佳士得集團旗下公司全部或部分擁有之拍賣品。該等拍賣品在目錄中於拍賣編號旁註有 △ 符號以資識別。

◊: 保證最低出售價

佳士得有時就某些受委託出售的拍賣品的拍賣成持有直接的經濟利益。通常為其向賣方保證無論拍賣的結果如何，賣方將就拍賣品的出售獲得最低出售價。這被稱為保證最低出售價。該等拍賣品在目錄中於拍賣編號旁註有 ◊ 號以資識別。

◆: 第三方保證 / 不可撤銷的競投

在佳士得已經提供最低出售價保證，如果拍賣品未能出售，佳士得將承擔遭受重大損失的風險。因此，佳士得有時選擇與第三方分擔該風險。在這種情況下，第三方向意在拍賣之前該拍賣品提交一份不可撤銷的書面競投。第三方因此承諾競投該拍賣品，如果沒有其它競投，等三方將以書面競投價格購買該拍賣品，除非有其它更高的競投。第三方因此承諾拍賣品未能出售的所有或部分風險。如果拍賣品未能出售，第三方可能承擔損失。該等拍賣品在目錄中注以符號◆以資識別。

第三方需要承擔風險，在自身不是成功競投人的情況下，會收取基於成交價計算的酬金。第三方亦可以就該拍賣品以超過書面競投的價格進行競投。如果第三方成功競投，則不會收取任何酬金。

我們要求第三方保證人向其客戶披露在給予保證的拍賣品持有的經濟利益。如果您通過顧問意見或委託代理人競投一件標示為有第三方融資的拍賣品，我們建議您應當要求您的代理人確認她 / 他是否在拍賣品持有經濟利益。

其他安排

佳士得可能訂立與競投無關的協議。這些協議包括佳士得向賣方就拍賣品銷售所得預付金額或者佳士得與第三方分擔風險，但並不要求第三方提供不可撤銷的書面競投或參與拍賣品的競投。因為上述協議與競投過程無關，我們不會在目錄中注以符號。

利益方的競投

如果競投人在拍賣品持有經濟利益並欲競投該拍賣品，我們將以拍賣場通知的方式知會所有競投者。該經濟利益可包括遺產受益人保留權利參與競投，遺產委託拍賣的拍賣品或者風險共擔安排下的合作方保留權利參與與競投拍賣品和 / 或通知我們其競投該拍賣品的意願。

請登錄 <http://www.christies.com/financial-interest/> 瞭解更多關於最低出售價保證以及第三方融資安排的說明。

如果佳士得在目錄中每一項拍賣品中均所有權或經濟利益，佳士得將不會於每一項拍賣品旁附註符號，但會於正文首頁聲明其權益。

有關繪畫、素描、版畫、小型畫、雕塑、裝置、錄像、書法及手繪瓷器

下列詞語於本目錄中具有以下意義。請注意本目錄中有關作者身份的所有聲明均按照本公司之業務規定及真品保證的條款而作出。

賣方應親自檢視各拍賣品的狀況，亦可向佳士得要求提供書面狀況報告。

有保留的標題

佳士得認是屬於該藝術家之作品

* 「傳」、「認為是...之作品」

指以佳士得有保留之意見認為，某作品大概全部或部份是藝術家之創作。

* 「...之創作室」及「...之工作室」

指以佳士得有保留之意見認為，某作品在某藝術家之創作室或工作室完成，可能在他監督下完成。

* 「...時期」

指以佳士得有保留之意見認為，某作品屬於該藝術家時期之創作，並且反映出該藝術家之影響。

* 「銀隨...風格」

指以佳士得有保留之意見認為，某作品具有某藝術家之風格，但未必是該藝術家門生之作品。

* 「具有...創作手法」

指以佳士得有保留之意見認為，某作品具有某藝術家之風格，但於較後時期完成。

* 「...複製品」

指以佳士得有保留之意見認為，某作品是某藝術家作品之複製品（任何日期）。

* 「簽名...」、「日期...」、「題章...」

指以佳士得有保留之意見認為，某作品由某藝術家簽名 / 寫上日期 / 題詞。

* 「附有...簽名」、「附有...之日期」、「附有...之題詞」、「款」

指以佳士得有保留之意見認為某簽名 / 某日期 / 題詞不是某藝術家所為。

古代、近現代印刷品之日期是指製造作品之日期 [或大概日期] 而不一定是作品印刷或出版之日。

* 於本目錄編列方法之說明中此詞語及其定義為對作者身份而言之有規限說明。雖然本詞語之使用，乃基於審慎研究及代表專家之意見，佳士得及委託人於目錄內使用此詞語及其所描述之拍賣品及其作者身份之真確及可信性，並不承擔及接受任何風險、義務或責任，而真品保證條款，亦不適用於此詞語所描述之拍賣品。

購買一系列貨批的選擇權

一組貨批內含多批相同批量、瓶容量及種類的名酒。競投將會由一系列貨批之中的第一貨批開始，成功競投的買家有權以相同的成交價購入系列中部分或全部貨批。若果第一貨批的買家未有進一步購入，該系列貨批的餘下貨批將會以相似的方式開放競投。佳士得建議對貨批的出價應在該系列貨批的第一貨批之上。如果出價被取代，佳士得將會自動把買家的出價置在下一相同貨批，如此類推。在所有情況下，有關出價均全權由拍賣官處理。

分類

內容中的波爾多分標標準僅作識別之用，並且根據 Médoc 1855 年正式的分類標準及其他標準來源。除註明外，所有名酒均在莊園內裝瓶。

舊酒的天然耗損及酒塞

在本目錄內列明的名酒均在印刷前確定內容正確，惟舊酒買家必須對自然程度的耗損、酒帽狀況、標簽、酒塞及各酒瓶的差異作出包容。恕不接受退貨。

耗損

名酒水位未能達至滿的水位之差距，有關差距會根據名酒之年期而有所不同，而在銷售前能通過檢驗確定的，均會在目錄中註明。本目錄以圖表的形式詳細說明水位與損耗量形容及解釋以方便閣下參考。

LEVEL/ULLAGE DESCRIPTIONS AND INTERPRETATIONS

(see notes below)

BORDEAUX

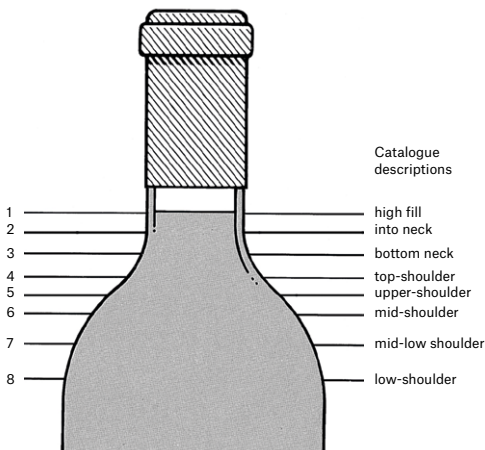

- 1 into neck: Level of young wines. Exceptionally good in wines over 10 years old.
- 2 bottom neck: Perfectly good for any age of wine. Outstandingly good for a wine of 20 years in bottle, or longer.
- 3 very top-shoulder
- 4 top-shoulder: Normal for any claret 15 years old or older.
- 5 upper-shoulder: Slight natural reduction through the easing of the cork and evaporation through cork and capsule. Usually no problem. Acceptable for any wine over 20 years old. Exceptional for pre-1950 wines.

BURGUNDY

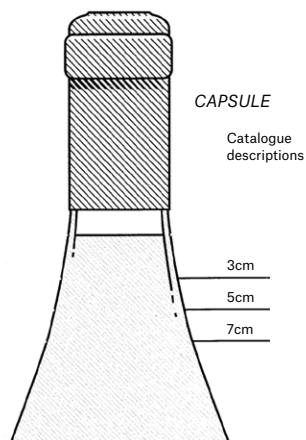

Catalogue descriptions

CAPSULE

Catalogue descriptions

1 high fill
2 into neck
3 bottom neck
4 top-shoulder
5 upper-shoulder
6 mid-shoulder
7 mid-low shoulder
8 low-shoulder

3cm
5cm
7cm

- 6 mid-shoulder: Probably some weakening of the cork and some risk. Not abnormal for wines 30/40 years of age. Estimates usually take this into account.
- 7 mid-low-shoulder: Some risk. Low estimates.
- 8 low-shoulder: Risky and usually only accepted for sale if wine or label exceptionally rare or interesting. Always offered with low estimate.

Because of the slope of shoulder it is impractical to describe levels as mid-shoulder, etc. Wherever appropriate the level between cork and wine will be measured and catalogued in centimetres.

The condition and drinkability of burgundy is less affected by ullage than its equivalent from Bordeaux. For example, a 5 to 7 cm. ullage in a 30-year-old burgundy can be considered normal, indeed good for age, 3.5 to 4 cm. excellent for age, even 7cm. rarely a risk.

BOTTLE SIZES

magnum	= two regular bottles	(1.5L)
marie-jeanne	= three regular bottles	(2.5L)
double-magnum	= four regular bottles	(3L)
jeroboam	= four regular bottles	(3L)
(Burgundy, Champagne)		
jeroboam	= six regular bottles	(5L)
(Bordeaux)		
(or 5 litres)		
impériale	= eight regular bottles	(6L)
(Bordeaux)		
methusalem	= eight regular bottles	(6L)
(Burgundy)		
balthazar	= sixteen regular bottles	(12L)
nebuchadnezzar	= twenty regular bottles	(15L)
melchior	= twenty-four regular bottles	(18L)

SPECIAL NOTICE

Though every effort is made to describe or measure the levels of older vintages, corks over 20 years old begin to lose their elasticity and levels can change between cataloguing and sale. Old corks have also been known to fail during or after shipment. **We therefore repeat that there is always a risk of cork failure with old wines and due allowance must be made for this. Under no circumstances can an adjustment of price or credit be made after delivery except under the terms stated in Paragraph I of the Conditions of Sale - Buying at Christie's. Unless otherwise stated, Bordeaux are château bottled and all wines are bottled in the country of production.**

Important note regarding opening of cases and listing of levels: Christie's general policy is to open all wood cases and to describe levels. Bidders must make allowances for reasonable variations in ullage which may be encountered in cases older than twenty years. Additionally, all wine younger than twenty years have levels bottom neck or better unless otherwise noted.

狀況 / 損耗量形容及解釋

(請細閱以下)

波爾多

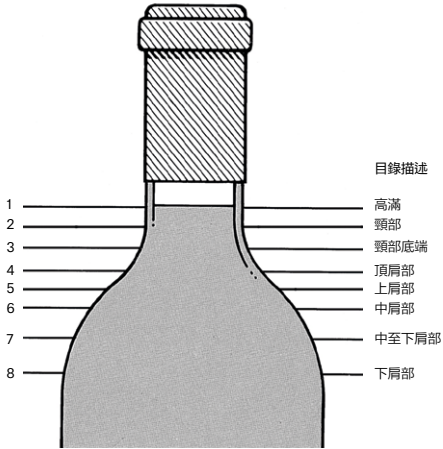

- 1 頸部：
新酒的正常水位。若酒齡超過 10 年的酒還保持這水位，是非常好的。
- 2 頸部底端：
對任何酒齡的酒來說，都是很好的，尤其是如酒齡是超過 20 年的酒。
- 3 最頂肩部
- 4 頂肩部：
正常的如酒齡是 15 年或以上。
- 5 上肩部：
因酒塞鬆懈及蒸發以至有少許自然的退減，一般是沒有問題的。可接受如酒齡超過 20 年。

目錄描述

- 高滿
- 頸部
- 頸部底端
- 頂肩部
- 上肩部
- 中肩部
- 中至下肩部
- 下肩部

- 6 中肩部：
酒塞可能有一些削弱，有一些風險，不是異常的如酒齡到達 30/40 年。估值通常會把此計算在內。
- 7 中至低肩部：
有些風險，低估值。
- 8 低肩部：
高風險及一般只會售賣當酒或招紙是很稀有或珍貴。常常也是低估值。

勃根地

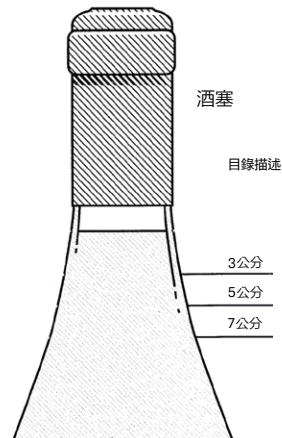

酒塞

目錄描述

- 3公分
- 5公分
- 7公分

由於肩部的斜度並不能夠形容中肩等的水位，在可能的情況下酒塞及名酒之間的距離將會以厘米量度及收錄。
勃根地酒的狀況及可飲用程度，較之於波爾多酒，較少受自然耗損影響。例如酒齡為三十年的勃根地酒有 5 至 7 厘米的自然耗損可視為正常。酒齡良好的，會有 3.5 至 4 厘米的自然耗損，酒齡超卓的甚至會有 7 厘米的自然耗損，很少具有風險。

酒瓶大小

magnum	= 2 個標準瓶 (1.5 公升)
marie-jeanne	= 3 個標準瓶 (2.5 公升)
double-magnum	= 4 個標準瓶 (3 公升)
jeroaboam (Burgundy, Champagne)	= 4 個標準瓶 (3 公升)
jeroaboam (Bordeaux)	= 6 個標準瓶 (5 公升) (或 5 升)
impériale (Bordeaux)	= 8 個標準瓶 (6 公升)
methuselah (Burgundy)	= 8 個標準瓶 (6 公升)
balthazar	= 16 個標準瓶 (12 公升)
nebuchadnezzar	= 20 個標準瓶 (15 公升)
melchior	= 24 個標準瓶 (18 公升)

特別通告

儘管已盡一切辦法去形容或量度較舊名酒的水位，超過 20 年的酒塞亦會開始失去其彈性，水位可能在收錄目錄及銷售期間改變。舊酒塞亦已知可能在運送或運抵後失效。佳士得因此重申舊酒的酒塞經常有損壞的風險，必須對此有適當的寬容。除出現在業務規定，買方須知第 1 段的情況，在任何情況下，在運送後均不可調整價格或退款。除註明外，所有波爾多酒均於莊園裝瓶，所有名酒均在生產國裝瓶。

有關打開酒箱及列明水位的重要註釋：佳士得一般的政策是打開所有木酒箱，並說明水位。按標者必須對酒齡 20 年及以上的名酒可能出現的自然耗損的合理差異有所寬容。此外，除另有註明，所有酒齡 20 年以下的名酒均有頸部底端或更佳的水位。

WORLDWIDE SALEROOMS AND OFFICES AND SERVICES

ARGENTINA
BUENOS AIRES
 +54 11 43 93 42 22
 Cristina Carlisle

AUSTRALIA
SYDNEY
 +61 (0)2 9326 1422
 Ronan Sulich

AUSTRIA
VIENNA
 +43 (0)1 533 881214
 Angela Bailou

BELGIUM
BRUSSELS
 +32 (0)2 512 88 30
 Roland de Lathuy

BERMUDA
BERMUDA
 +1 401 849 9222
 Betsy Ray

BRAZIL
RIO DE JANEIRO
 +5521 2225 6553
 Candida Sodre

SÃO PAULO
 +5511 3061 2576
 Nathalie Lenci

CANADA
TORONTO
 +1 416 960 2063
 Brett Sherlock

CHILE
SANTIAGO
 +56 2 2 2631642
 Denise Ratnoff
 de Lira

COLOMBIA
BOGOTA
 +571 635 54 00
 Juanita Madrinan

DENMARK
COPENHAGEN
 +45 3962 2377
 Birgitte Hillingsø
 (Consultant)
 + 45 2612 0092
 Rikke Juel Brandt
 (Consultant)

**FINLAND AND
 THE BALTIC STATES**
HELSINKI
 +358 40 5837945
 Barbro Schauman
 (Consultant)

FRANCE
**BRITTANY AND
 THE LOIRE VALLEY**
 +33 (0)6 09 44 90 78
 Virginie Gregory
 (Consultant)

**GREATER
 EASTERN FRANCE**
 +33 (0)6 07 16 34 25
 Jean-Louis Janin Daviet
 (Consultant)

NORD-PAS DE CALAIS
 +33 (0)6 09 63 21 02
 Jean-Louis Brémilts
 (Consultant)

-PARIS
 +33 (0)1 40 76 85 85

**POITOU-CHARENTE
 AQUITAINE**
 +33 (0)5 56 81 65 47
 Marie-Cécile Moueix

**PROVENCE -
 ALPES CÔTE D'AZUR**
 +33 (0)6 71 99 97 67
 Fabienne Albertini-Cohen

RHÔNE ALPES
 +33 (0)6 61 81 82 53
 Dominique Pierron
 (Consultant)

GERMANY
DÜSSELDORF
 +49 (0)21 14 91 59 352
 Arno Verkade

FRANKFURT
 +49 (0)173 317 3975
 Anja Schaller (Consultant)

HAMBURG
 +49 (0)40 27 94 073
 Christiane Grafín
 zu Rantzau

MUNICH
 +49 (0)89 24 20 96 80
 Marie Christine Grafín
 Huyn

STUTTGART
 +49 (0)71 12 26 96 99
 Eva Susanne
 Schweizer

INDIA
-MUMBAI
 +91 (22) 2280 7905
 Sonal Singh

DELHI
 +91 (011) 6609 1170
 Sanjay Sharma

INDONESIA
JAKARTA
 +62 (0)21 7278 6268
 Charmie Hamami

ISRAEL
TEL AVIV
 +972 (0)3 695 0695
 Roni Glat-Baharaff

ITALY
-MILAN
 +39 02 303 2831

ROME
 +39 06 686 3333
 Marina Cicogna

NORTH ITALY
 +39 348 3131 021
 Paola Gradi
 (Consultant)

TURIN
 +39 347 2211 541
 Chiara Massimello
 (Consultant)

VENICE
 +39 041 277 0086
 Bianca Arrivabene Valenti
 Gonzaga (Consultant)

BOLOGNA
 +39 051 265 154
 Benedetta Possati
 Vittori Venenti (Consultant)

GENOA
 +39 010 245 3747
 Rachele Guicciardi
 (Consultant)

FLORENCE
 +39 055 219 012
 Alessandra Niccolini di
 Camugliano (Consultant)

**CENTRAL &
 SOUTHERN ITALY**
 +39 348 520 2974
 Alessandra Allaria
 (Consultant)

JAPAN
TOKYO
 +81 (0)3 6267 1766
 Chie Banta

MALAYSIA
KUALA LUMPUR
 +60 3 6207 9230
 Lim Meng Hong

MEXICO
MEXICO CITY
 +52 55 5281 5546
 Gabriela Lobo

MONACO
 +377 97 97 11 00
 Nancy Dotta

THE NETHERLANDS
-AMSTERDAM
 +31 (0)20 57 55 255

NORWAY
OSLO
 +47 975 800 78
 Katinka Traaseth
 (Consultant)

**PEOPLES REPUBLIC
 OF CHINA**
BEIJING
 +86 (0)10 8583 1766

-HONG KONG
 +852 2760 1766

-SHANGHAI
 +86 (0)21 6355 1766

PORTUGAL
LISBON
 +351 919 317 233
 Mafalda Pereira Coutinho
 (Consultant)

RUSSIA
MOSCOW
 +7 495 937 6364
 +44 20 7389 2318
 Katya Vinokurova

SINGAPORE
SINGAPORE
 +65 6735 1766
 Nicole Tee

SOUTH AFRICA
CAPE TOWN
 +27 (21) 761 2676
 Juliet Lomborg
 (Independent Consultant)

**DURBAN &
 JOHANNESBURG**
 +27 (31) 207 8247
 Gillian Scott-Berning
 (Independent Consultant)

WESTERN CAPE
 +27 (44) 533 5178
 Annabelle Conyngham
 (Independent Consultant)

SOUTH KOREA
SEOUL
 +82 2 720 5266
 Hye-Kyung Bae

SPAIN
BARCELONA
 +34 (0)93 487 8259
 Carmen Schjaer

MADRID
 +34 (0)91 532 6626
 Juan Varez
 Dalia Padilla

SWEDEN
STOCKHOLM
 +46 (0)73 645 2891
 Claire Ahman (Consultant)
 +46 (0)70 9369 201
 Louise Dyhén
 (Consultant)

SWITZERLAND
-GENEVA
 +41 (0)22 319 1766
 Eveline de Proyart

-ZURICH
 +41 (0)44 268 1010
 Dr. Bertold Mueller

TAIWAN
TAIPEI
 +886 2 2736 3356
 Ada Ong

THAILAND
BANGKOK
 +66 (0)2 652 1097
 Satima Tanabe

TURKEY
ISTANBUL
 +90 (852) 558 7514
 Eda Kehale Argün
 (Consultant)

**UNITED ARAB
 EMIRATES**
-DUBAI
 +971 (0) 4 425 5647

UNITED KINGDOM
**-LONDON,
 KING STREET**
 +44 (0)20 7839 9060

**-LONDON,
 SOUTH KENSINGTON**
 +44 (0)20 7930 6074

**NORTH AND
 NORTHEAST**
LISBON
 +44 (0)20 3219 6010
 Thomas Scott

**NORTHWEST
 AND WALES**
 +44 (0)20 7752 3033
 Jane Blood

SOUTH
 +44 (0)1730 814 300
 Mark Wrey

SCOTLAND
 +44 (0)131 225 4756
 Bernard Williams
 Robert Lagneau
 David Bowes-Lyon
 (Consultant)

ISLE OF MAN
 +44 (0)20 7389 2032

CHANNEL ISLANDS
 +44 (0)20 7389 2032

IRELAND
 +353 (0)87 638 0996
 Christine Ryall
 (Consultant)

UNITED STATES
CHICAGO
 +1 312 787 2765
 Lisa Cavanaugh

DALLAS
 +1 214 599 0735
 Capera Ryan

HOUSTON
 +1 713 802 0191
 Jessica Phifer

LOS ANGELES
 +1 310 385 2600

MIAMI
 +1 305 445 1487
 Jessica Katz

NEWPORT
 +1 401 849 9222
 Betsy D. Ray

-NEW YORK
 +1 212 636 2000

SAN FRANCISCO
 +1 415 982 0982
 Ellanor Notides

AUCTION AND OTHER SERVICES

PRIVATE SALES
 HK: +852 2978 6871
 Fax: +852 2760 1767
 Email: privatesaleservicecentre@christies.com

CHRISTIE'S EDUCATION

New York
 Tel: +1 212 355 1501
 Fax: +1 212 355 7370
 Email: newyork@christies.edu

Hong Kong
 Tel: +852 2978 6768
 Fax: +852 2525 3856
 Email: hongkong@christies.edu

London
 Tel: +44 (0)20 7665 4350
 Fax: +44 (0)20 7665 4351
 Email: london@christies.edu

CHRISTIE'S INTERNATIONAL REAL ESTATE

New York
 Tel: +1 212 468 7182
 Fax: +1 212 468 7141
 Email: info@christiesrealestate.com

London
 Tel: +44 (0)20 7389 2551
 Fax: +44 (0)20 7389 2168
 Email: info@christiesrealestate.com

Hong Kong
 Tel: +852 2978 6788
 Fax: +852 2845 2646
 Email: info@christiesrealestate.com

CHRISTIE'S FINE ART STORAGE SERVICES

New York
 Tel: +1 212 974 4579
 Email: newyork@cfass.com

Singapore
 Tel: +65 6543 5252
 Email: singapore@cfass.com

• DENOTES SALEROOM

ENQUIRIES – Call the Saleroom or Office
 For a complete salerooms & offices listing go to christies.com

EMAIL – info@christies.com

CHRISTIE'S HONG KONG WINE COLLECTION AND STORAGE

All wines offered for auction in this catalogue are lying in Christie's appointed cellar, Crown Wine Cellars.

Buyers wishing to collect from the storage facility directly may do so by prior arrangement. Crown Wine Cellars will only release the lots upon your signature of a Christie's Collection Order. Request for deliveries can be made after receipt of cleared funds and must be at least 2 business days prior to date of delivery. All shipping charges, local delivery charges, transit insurance and packing will be at the expense of the buyers. All charges will have to be prepaid to Christie's before shipment can be effected. All breakages or missing bottles must be reported to Christie's within three days of collection or delivery of the wine lots. To arrange the pick-up or delivery of your purchase, please contact Mr. Kelvin Pun of Crown Wine Cellars at +852 2453 3530.

If lots are not collected within thirty-five calendar days following the sale, Crown Wine Cellars Limited will charge you and you will have to pay all storage charges incurred from the thirty-sixth calendar day following the sale for the period while the lot(s) are stored at Crown Wine Cellars Limited's storage facility. Crown Wine Cellars Limited will invoice the buyers directly. Buyers agree that Christie's will provide the buyers' contact details to Crown Wine Cellars Limited for the purposes of invoicing and collection of storage fees.

Local Delivery Charges for normal orders (All prices are subject to change)

Urgent, express orders and other areas not mentioned below will be quoted separately.

Delivery/Collection			
Bottle	Hong Kong Island	Kowloon & New Territories	Lantau Island & Ma Wan
1-6	HKD300	HKD210	HKD330
7-12	HKD350	HKD260	HKD380
13-48	HKD450	HKD360	HKD480
49-240	HKD620	HKD530	HKD650

* For 241 bottles and above, please contact Crown Wine Cellars at Tel: +852 2453 3530.

** Delivery Charges include insurance.

Delivery Schedule: Monday to Friday 11:00-17:00
Saturday before 12:00

The storage facility information is listed below:

Storage Facility (Tuen Mun)

Contact: Mr. Kelvin Pun/Ms. Angel Lam
Email: kpun@crownew.com
Tel: +852 2453 3530
Address: 2/F, Crown Data Centre 1,
6 Kin Fung Circuit, Tuen Mun, N.T.

Office Hours: Monday to Friday 10:00-12:30 and 14:00-17:30
Saturday 10:00-12:30

Overseas Delivery

For designated countries, Christie's will be pleased to assist with making arrangements for the packing, shipping and transit insurance of the purchased lots at the buyer's request and expense upon receipt of all outstanding payment in cleared funds. Christie's will obtain quotes at the buyer's request. All shipping charges have to be agreed and pre-paid before shipment can be effected. Christie's charges a 10% administrative fee on the shipping quote for managing your shipment. Please be reminded that all shipping quotes are exclusive of any tax and/or duties imposed by government authorities. It is the Buyer's sole responsibility to obtain any required export or import licenses.

Please contact our Post-Sale Services Department +852 2760 1766 or postsalesia@christies.com for further information.

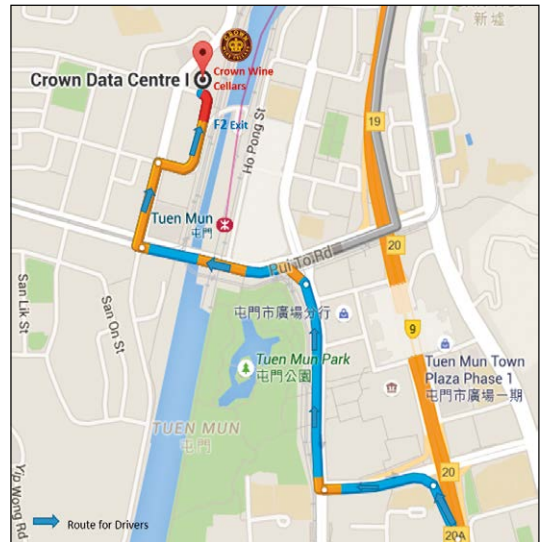

香港佳士得名酒提取及儲存

所有在此拍賣的名酒現儲存於佳士得委任的酒窖 - Crown Wine Cellars Limited。

買家如欲直接從儲存設施提貨，請作提前通知以作安排。買家需要簽署由佳士得發出的提貨通知單，以便 Crown Wine Cellars Limited 發放拍賣品。買家支付所有費用後可提出貨品付運的要求，但有關要求必需於付運日期前的兩個工作天提出。買家須負責提取或安排本地送遞及/或運送。所有運費、本地送遞、運輸保險及包裝的費用將由買家負責。所有費用要在運送前預先繳付予佳士得，才會進行付運。所有破損或遺漏瓶數，必須在收到拍賣品後的三天內向佳士得報告。有關安排運送及提取事宜，請聯絡 Crown Wine Cellars Limited 潘先生，電話為 +852 2453 3530。

如果已購買的名酒在拍賣日後三十五個日曆天內仍未提取，即表示授權 Crown Wine Cellars Limited 儲存該名酒，有關儲存費用會由買家支付，直至該名酒被提取為止。Crown Wine Cellars Limited 將會向買家收取儲存費用並直接向買家發出發票。買家同意佳士得向 Crown Wine Cellars Limited 提供買家之資料，作為發出發票和收取儲存費之用途。

本地普通運單付運費用（價格或有更改）

加急運單及其他不在運輸範圍內區域的運單，請向佳士得名酒部查詢。

送貨 / 收貨			
數量	香港島	九龍及新界	大嶼山及馬灣
1-6 瓶	港幣 300	港幣 210	港幣 330
7-12 瓶	港幣 350	港幣 260	港幣 380
13-48 瓶	港幣 450	港幣 360	港幣 480
49-240 瓶	港幣 620	港幣 530	港幣 650

* 241 瓶及以上，請向 Crown Wine Cellars 查詢 +852 2453 3530。

** 送貨收費包括保險費。

送貨時間：星期一至五 上午十一時至下午五時
星期六 正午十二時前

有關儲存設施資料列舉如下：

儲存設施（屯門）

聯絡人：潘先生 / 林小姐
電郵：kpun@crownwww.com
辦公室電話：+852 2453 3530
地址：新界屯門建豐街 6 號
嘉柏中心 1 期 2 樓

酒窖辦公時間：星期一至五 上午十時正至下午十二時三十分及
下午二時正至下午五時三十分
星期六 上午十時正至下午十二時三十分

海外付運

若付運到其他指定國家，在買方以清算現金全數付清所有欠款後，佳士得可依照買家之要求，代為安排包裝、付運及運輸保險事宜，買家須繳付有關收費。佳士得會根據買家要求，提供報價給予買家。所有付運須於買家同意該運費及繳付後方作安排。佳士得會收取付運報價的 10% 以作行政費用。請注意所有付運報價不包括任何稅項及 / 或出入口稅項。買家須負責取得所有相關的進出口牌照。

詳情請向香港佳士得售後服務部 +852 2760 1766 或 postsaleasia@christies.com 查詢。

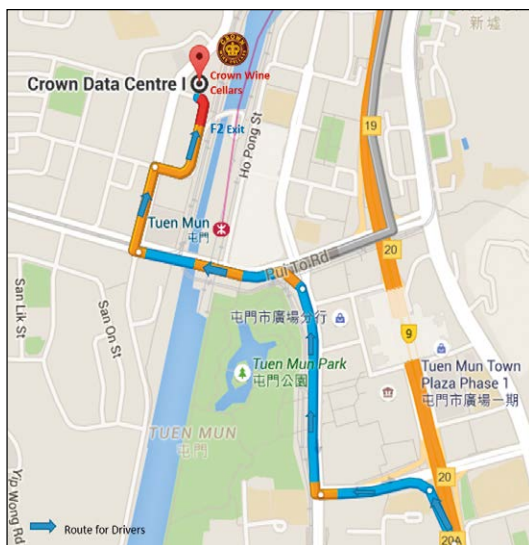

FINE AND RARE WINES

FEATURING EXCEPTIONAL
PRIVATE COLLECTIONS

SATURDAY 26 NOVEMBER 2016
AT 1.00 PM

Grand Hall,
Hong Kong Convention and Exhibition Centre,
No.1 Expo Drive, Wanchai, Hong Kong

CODE NAME: **VERTICAL**
SALE NUMBER: **12577**
LOT NUMBER: **6001-6494**

Please note that Christie's does not accept payment from third parties, including agents, and that invoice details cannot be changed after the sale.

BID ONLINE FOR THIS SALE AT
WWW.CHRISTIES.COM

BIDDING INCREMENTS

Bidding generally starts below the **low estimate** and increases in steps (bid increments) of up to 10 per cent. The auctioneer will decide where the bidding should start and the bid increments. Written bids that do not conform to the increments set below may be lowered to the next bidding interval.

HK\$1,000 to HK\$2,000	by HK\$100s
HK\$2,000 to HK\$3,000	by HK\$200s
HK\$3,000 to HK\$5,000	by HK\$200, 500, 800 (ie: HK\$4,200, HK\$4,500, HK\$4,800)
HK\$5,000 to HK\$10,000	by HK\$500s
HK\$10,000 to HK\$20,000	by HK\$1,000s
HK\$20,000 to HK\$30,000	by HK\$2,000s
HK\$30,000 to HK\$50,000	by HK\$2,000, 5,000, 8,000 (ie: HK\$32,000, HK\$35,000, HK\$38,000)
HK\$50,000 to HK\$100,000	by HK\$5,000s
HK\$100,000 to HK\$200,000	by HK\$10,000s
HK\$200,000 to HK\$300,000	by HK\$20,000s
HK\$300,000 to HK\$500,000	by HK\$20,000, 50,000, 80,000 (ie: HK\$320,000, HK\$350,000, HK\$380,000)
HK\$500,000 to HK\$1,000,000	by HK\$50,000s
Above HK\$1,000,000	at auctioneer's discretion

The auctioneer may vary the increments during the course of the auction at his or her own discretion.

- I request Christie's to bid on the stated **lots** up to the maximum bid I have indicated for each **lot**.
- I understand that if my bid is successful the amount payable will be the sum of the **hammer price** and the **buyer's premium (together with any taxes chargeable on the hammer price and buyer's premium in accordance with the Conditions of Sale - Buying at Christie's)**. The **buyer's premium** rate shall be an amount equal to 25% of the **hammer price** of each **lot** up to and including HK\$ 1,200,000, 20% on any amount over HK\$ 1,200,000 up to and including HK\$ 20,000,000 and 12% of the amount above HK\$ 20,000,000. For wine there is a flat rate of 22.5% of the **hammer price** of each **lot** sold.
- I agree to be bound by the Conditions of Sale - Buying at Christie's printed in the catalogue.
- I understand that if Christie's receive written bids on a **lot** for identical amounts and at the auction these are the highest bids on the lot, Christie's will sell the **lot** to the bidder whose written bid it received and accepted first.
- Written bids submitted on "no reserve" **lots** will, in the absence of a higher bid, be executed at approximately 50% of the **low estimate** or at the amount of the bid if it is less than 50% of the **low estimate**.

I understand that Christie's written bid service is a free service provided for clients and that, while Christie's will be as careful as it reasonably can be, Christie's will not be liable for any problems with this service or loss or damage arising from circumstances beyond Christie's reasonable control.

Auction Results: +852 2760 1766

The auctioneer will usually only accept bids for High Value Lots if a deposit has been arranged prior to the day of sale and the High Value Lot pre-registration application has been completed. High Value Lot Deposit Forms should be sent to the Bids Department by email to bidsasia@christies.com. I understand that if I have not completed the High Value Lot pre-registration before sale I will not be permitted to bid for High Value Lots.

If you are not successful in any bid and do not owe any Christie's group company any money, the deposit will be refunded to you by way of wire transfer or such other method as determined by Christie's. Please make sure that you provide your bank details in the High Value Lot Deposit Forms.

Written Bids Form

Christie's Hong Kong

Written bids must be received at least 24 hours before the auction begins. Christie's will confirm all bids received by e-mail by return e-mail. If you have not received confirmation within one business day, please resubmit your bid(s) or contact: Bid Department.
Tel: +852 2978 9910 Email: bidsasia@christies.com.

Client Number (if applicable)

Client Name (please print)

Address

Post Code

Contact Number (Mobile)

(Fax)

Email

Please tick if you do not want to receive your invoice by email.

Please tick if you prefer not to receive information about our upcoming sales by e-mail

I HAVE READ AND UNDERSTOOD THIS WRITTEN BID FORM AND THE CONDITIONS OF SALE - BUYING AT CHRISTIE'S

Signature

Date

If you have not previously bid or consigned with Christie's, please attach copies of the following documents. **Individuals:** government-issued photo identification (such as a photo driving licence, national identity card, or passport) and, if not shown on the ID document, proof of current address, for example a utility bill or bank statement. **Corporate clients:** certificate of incorporation, proof of company address, photo ID copy of the authorized bidder, letter of authorization duly signed by the director or the legal representative and, where applicable, chopped with company stamp and official document listing directors and shareholders. **Other business structures such as trusts, offshore companies or partnerships:** please contact the Credit Department at + 852 2978 6870 for advice on the information you should supply. If you are registering to bid on behalf of someone who has not previously bid or consigned with Christie's, please attach identification documents for yourself as well as the party on whose behalf you are bidding, together with a signed letter of authorisation from that party.

New clients, clients who have not made a purchase from any Christie's office within the last 12 months, and those wishing to spend more than on previous occasions will be asked to supply a bank reference and/or a recent bank statement and we may also require a deposit as we deem appropriate as a condition of allowing you to bid. If you are asked to provide a deposit, you will need to arrange payment with us. Your bidder registration will not be considered complete until we receive payment of the deposit in full and cleared funds.

PLEASE PRINT CLEARLY

Lot number (in numerical order)	Number of Lots required	Maximum Bid HK\$ (excluding buyer's premium)

CHRISTIE'S 佳士得

佳士得名釀

二〇一六年 十一月二十六日
星期六 下午一時正

香港灣仔博覽道1號
香港會議展覽中心大會堂

編號名稱：**VERTICAL**
拍賣編號：**12577**
拍賣品編號：**6001-6494**

佳士得不接受包括代理人在內之第三方支付款；付款資料於拍賣會完結後將不能更改。

參與網絡競投可登入佳士得網站www.christies.com

競投價遞增幅度

競投一般由低於**低端估價**開始，通常每次喊價之遞增幅度（競投價遞增幅度）最高為10%，拍賣官會自行決定競投開始價位及遞增幅度。書面競投價若與下列之遞增幅度不一致，將被調低至下一個喊價金額：

競投價	每次喊價之遞增金額
1,000-2,000 港元	100 港元
2,000-3,000 港元	200 港元
3,000-5,000 港元	200, 500, 800 港元 (例 4,200, 4,500, 4,800 港元)
5,000-10,000 港元	500 港元
10,000-20,000 港元	1,000 港元
20,000-30,000 港元	2,000 港元
30,000-50,000 港元	2,000, 5,000, 8,000 港元 (例 32,000, 35,000, 38,000 港元)
50,000-100,000 港元	5,000 港元
100,000-200,000 港元	10,000 港元
200,000-300,000 港元	20,000 港元
300,000-500,000 港元	20,000, 50,000, 80,000 港元 (例 320,000, 350,000, 380,000 港元)
500,000-1,000,000 港元	50,000 港元
1,000,000 港元或以上	拍賣官自行決定

在拍賣時拍賣官可酌情更改每次增加之額度。

- 茲請求佳士得就本表格所列的**拍賣品**進行競投，直至本表格所列的最高出價。
- 本人知悉如競投成功，本人應付之購買款項為**成交價及買方酬金（以及所有基於成交價和買方酬金而產生的稅費，及符合業務規定-買方須知）**。買方酬金費率按每件**拍賣品**成交價首港幣1,200,000元之25%，加逾港幣1,200,000元以上至20,000,000元部份之20%；加逾港幣20,000,000元以上之12%計算。名顯的**買方酬金**是按每件**拍賣品**成交價之22.5%。
- 本人同意接受本目錄中所列之業務規定的管限。
- 本人理解如佳士得收到多個競投價相等的書面競投，而在拍賣時此等競投價乃該**拍賣品**的最高出價，則該**拍賣品**售給最先送達其書面競投書給本公司之競投人。
- 如果您以書面競投一件**“沒有底價”**的**拍賣品**，而且沒有其他更高叫價，我們會為您以**低端估價**的50%進行競投；或如果您的投標價低於**低端估價**的50%，則以您的投標價進行競投。

本人亦明白，佳士得的書面競投服務為一項向客戶提供的免費服務，佳士得會合理謹慎進行，佳士得不曾就任何在佳士得控制的範圍以外產生的損失或賠償負責。

拍賣結果查詢：+852 2760 1766

拍賣官一般僅接受已於拍賣日前繳付保證金並已完成高額拍賣品預先登記人士之高額拍賣品競投。請將已填妥之高額拍賣品之登記表格電郵 bidsasia@christies.com 至投標部。本人知悉若本人未於拍賣前完成高額拍賣預先登記，本人將不獲准競投高額拍賣品。

若閣下未能成功競投任何**拍賣品**，對佳士得或**佳士得集團**其他公司亦無任何欠款，保證金將以電匯方式或佳士得決定之其他方式還閣下。請確保閣下已提供有關之銀行資料詳情。

書面競投表格

香港佳士得

書面競投必須在拍賣開始前至少 24 小時收到。

佳士得公司將以電郵確認收到閣下電郵之書面競投表格。如您在一個工作日內未能收到確認，請重新遞交書面競投表格或聯繫投標部。

電話：+852 2978 9910 電郵：bidsasia@christies.com

客戶編號（若適用）

客戶名稱（請用正楷填寫）

地址

郵編

聯絡電話（手提電話） 傳真

電郵

如閣下選擇不以電郵方式收取發票，請於方格內劃上「✓」號。

如閣下不希望透過電郵接收本公司將舉行的拍賣、活動或其他由佳士得集團及其聯營公司提供的服務資料，請於方格內劃上「✓」號。

我本人已細閱並理解本書面競投表格及業務規定。買方須知。

簽名 日期

如閣下未曾於佳士得競投或託售**拍賣品**，請附上以下文件之副本。個人：政府發出附有相片的身分證明文件（如國民身分證或護照），及（如身分證明文件未有顯示現時住址）現時住址證明，如公用事業帳單或銀行月結單。**公司客戶**：公司註冊證書、公司地址證明、被授權競投者附有相片的身分證明文件，由公司董事或法人按公司規定簽署及（若有）蓋有公司章的競投授權書，以及列出所有董事及股東的公司文件。**其他業務結構**，如**信託機構**、**離岸公司**或**合夥公司**：請與信用部聯絡，以諮詢閣下須提供何種資料，電話為+852 2978 6870。如閣下登記代表未曾於佳士得競投或託售**拍賣品**人士競投，請附上閣下本人的身分證明文件，以及閣下所代表競投人士的身分證明文件，連同該人士簽發的授權書。

新客戶、過去十二個月內未有在佳士得投得**拍賣品**，及本次擬出價金額高於過往之客戶，須提供銀行信用證明及/或近期的銀行月結單，亦或須繳付本公司指定的有關保證金作為允許閣下競投的先決條件。如閣下被要求提供保證金，閣下需與我們聯繫以安排付款。閣下的競投申請會在我們收到保證金的全額付款後方可作實。

請用正楷填寫清楚

拍賣品編號 (按數字排序)	拍賣品數量	最高競投價 (港幣) (買方酬金不計在內)



BIDDER REGISTRATION FORM

Paddle No.

We encourage new clients to register at least 48 hours in advance of a sale to allow sufficient time to process the registration.

Please complete and sign this form and send it to us by email registrationasia@christies.com.

A Bidder's Detail

Personal Account: Account Holder Authorised Agent (Name)

Authorisation Letter and ID (if applicable): Attached In System/previously provided

Company Account: I am (name and position)

Authorisation Letter and ID (if applicable): Attached In System/previously provided

Account No.

Account Name

Business Registration No.

Invoice Address Room/Flat Floor Block

Building/Estate

Street Address

City/District Post/Zip Code

County/Province/State Country

The name and address given above will appear on the invoice for lots purchased with your assigned paddle for this registration. Please check that the details are correct as the invoice cannot be changed after the sale.

Country Code Phone No. Email

B Identity Documents and Financial References

If you have not previously bid or consigned with Christie's, please provide copies of the following documents. **Individuals:** government-issued photo identification (such as a national identity card or passport) and, if not shown on the ID document, proof of current address, for example a utility bill or bank statement. **Corporate clients:** a certificate of incorporation, proof of company address, photo ID copy of the authorized bidder, letter of authorization duly signed by the director or the legal representative and, where applicable, chopped with company stamp and official document listing directors and shareholders. **Other business structures such as trusts, offshore companies or partnerships:** please contact the Credit Department at +852 2978 6870 for advice on the information you should supply. If you are registering to bid on behalf of someone who has not previously bid or consigned with Christie's, please attach identification documents for yourself as well as the person on whose behalf you are bidding, together with a signed letter of authorisation from the person. New clients, clients who have not made a purchase from any Christie's office within the last 12 months, and those wishing to spend more than on previous occasions will be asked to supply a bank reference and/or a recent bank statement and we may also require a deposit as we deem appropriate as a condition of allowing you to bid. If you are asked to provide a deposit, you will need to arrange payment with us. Your bidder registration will not be considered complete until we receive payment of the deposit in full and cleared funds.

High Value Lots Paddle Registration:

Do you require a High Value Lot ("HVL") paddle? Yes No

You will need a HVL paddle if you intend to bid on: (i) any lot in the Asian 20th Century & Contemporary Art Evening Sale; The Pioneers or (ii) a lot the low estimate of which is HK\$ 8 million or above. The auctioneer will only take bids on High Value Lots from bidders holding HVL paddles. To secure your HVL paddle, you will need to pay a HVL deposit, which we will calculate for you. Generally it will be the higher of: (i) HK\$ 1 million or (ii) 20% of the aggregate low estimates of the HVLs you intend to bid on; or (iii) such other amount as we may determine from time to time. You can pay your HVL deposit using any of the following methods: credit card(s) acceptable to Christie's; wire transfer; cashier order or cheque. We cannot accept payment from third parties and agents. The HVL registration procedure applies even if you have already registered to bid in our sales on other lots. Please allow at least 48 hours for processing of your HVL registration. We reserve the right to change our HVL registration procedure and requirements from time to time without notice.

Please indicate the bidding level you require:

- HK \$ 0 - 500,000 HK \$ 500,001 - 2,000,000 HK \$ 2,000,001 - 4,000,000
- HK \$ 4,000,001 - 8,000,000 HK \$ 8,000,001 - 20,000,000 HK \$ 20,000,000 +

C Sale Registration

Please register me for the following sessions:

- | | |
|--|---|
| <input type="checkbox"/> 12576 Fine and Rare Wines: A Gentleman's Collection | <input type="checkbox"/> 12578 Important Watches |
| <input type="checkbox"/> 12577 Fine and Rare Wines Featuring Exceptional Private Collections | <input type="checkbox"/> 12561 Fine Chinese Classical Paintings and Calligraphy |
| <input type="checkbox"/> 14617 The Pioneers | <input type="checkbox"/> 12562 Fine Chinese Modern Paintings |
| <input type="checkbox"/> 12520 Asian 20th Century & Contemporary Art (Evening Sale) | <input type="checkbox"/> 12579 Hong Kong Magnificent Jewels |
| <input type="checkbox"/> 12521 Asian Contemporary Art (Day Sale) | <input type="checkbox"/> 12675 Chinese Ceramics From The Yangdetang Collection |
| <input type="checkbox"/> 12523 Asian 20th Century Art (Day Sale) | <input type="checkbox"/> 12587 Handbags & Accessories |
| <input type="checkbox"/> 12560 Chinese Contemporary Ink | <input type="checkbox"/> 12563 Important Chinese Ceramics and Works of Art |

D Collection and Shipment

Please select one of the following options:

- I will collect my purchased lot(s).
- Please provide a shipping quotation to my account address/the below address:
-
-

E Declarations

- I have read the "Conditions of Sale - Buying at Christie's" and "Important Notices and Explanation of Cataloguing Practice" printed in the sale catalogue, as well as the "No Third Party Payment Notice" and agree to be bound by them.
 - I have read the data collection section of the conditions of sale printed in the sale catalogue and agree to be bound by its terms.
 - The auctioneer will usually only accept bids for high value lots if a deposit has been arranged before the day of the auction and the high value lot pre-registration application has been completed. I understand that if I have not completed the high value lot pre-registration before the auction I will not be permitted to bid for high value lots.
 - If you are not successful in any bid and do not owe any Christie's group company any money, the deposit will be refunded to you by way of wire transfer or such other method as determined by Christie's. please make sure that you provide your bank details to us.
- Please tick if you are a new client and would like to receive information about sales, events and other services offered by the Christie's group and its affiliates by e-mail. You can opt-out of receiving this information at any time.
- Invoice will be sent by email. Please tick if you do NOT wish to receive your invoice by email.

Name Signature Date

Christie's Hong Kong Limited

22nd Floor Alexandra House, 18 Chater Road, Central, Hong Kong Tel: +852 2760 1766
www.christies.com

投標者登記表格

競投牌編號

建議新客戶於拍賣舉行前至少 48 小時辦理登記，以便有充足時間處理登記手續。

請填妥並簽署本表格然後電郵至 registrationasia@christies.com。

A 投標者資料

個人名義競投： 本人 代理人 (姓名)

授權書及身份證明文件 (如適用)： 現附上 在佳士得記錄上 / 已提供

公司名義競投： 本人是 (姓名和職位)

授權書及身份證明文件 (如適用)： 現附上 在佳士得記錄上 / 已提供

客戶編號

客戶名稱

商業登記編號

客戶地址 室 樓層

大廈 / 屋苑

街道

城市 / 區 郵區編號

縣 / 省 / 州 國家

客戶名稱及地址會列印在附有是次登記之競投牌編號的發票上；付款資料於拍賣會完結後將不能更改，請確定以上資料確實無誤

國家及地區代碼 電話號碼 電郵地址

B 身份證明文件及財務證明

如閣下未曾於佳士得競投或託售拍賣品，請提供以下文件之副本。個人：政府發出附有相片的身份證明文件 (如國民身份證或護照)，及 (如身份證明文件未有顯示現時住址) 現時住址證明，如公用事業帳單或銀行月結單。公司客戶：公司註冊證書、公司地址證明、被授權競投者附有相片的身份證明文件，由公司董事或法人按公司規定簽署及 (若有) 蓋有公司章的競投授權書，以及列出所有董事及股東的公司文件。其他業務結構，如信託結構、離岸公司或合夥公司：請與信用部聯絡，以諮詢閣下須提供何種資料。電話為：+852 2978 6870。如閣下登記代表未曾於佳士得競投或託售拍賣品人士競投，請附上閣下本人的身份證明文件，以及閣下所代表競投人士的身份證明文件，連同該人士簽署的授權書。新客戶、過去十二個月內未有在佳士得投得拍賣品，及本次擬出價金額高於過往之客戶，須提供銀行信用證明及 / 或近期的銀行月結單，亦或須繳付本公司指定的有關保證金作為允許閣下競投的先決條件。如閣下被要求提供保證金，閣下需與我們聯繫以安排付款。閣下的競投申請會在我們收到保證金的全額付款後方可作實。

高額拍賣品競投牌登記：

閣下是否需要高額拍賣品競投號碼牌？ 是 否

如閣下有意競投 (i) 佳士得亞洲二十世紀及當代藝術晚間拍賣，先鋒薈萃之任何拍賣品；或 (ii) 其他類別拍賣品估價為港幣 8,000,000 元或以上的拍賣品，必須預先登記領取高額拍賣品競投號碼牌。對於高額拍賣品拍賣官只會接受持有高額拍賣品競投號碼牌的競投者出價。閣下需繳付保證金以領取高額拍賣品競投號碼牌。保證金一般為 (i) 港幣 1,000,000 元；或 (ii) 閣下擬競投的全部拍賣品低估值總額之 20%；或 (iii) 其他我們不時設定的金額 (以較高者為準)。閣下可以佳士得接受之信用卡、電匯、本票或支票繳付保證金。請注意佳士得概不接受第三方或代理人代付之款項。即使閣下已於佳士得其他拍賣登記，閣下仍需為高額拍賣品按高額拍賣品登記程序進行登記。請於拍賣舉行前至少 48 小時辦理登記，以確保有充足時間處理閣下的高額拍賣品登記手續。佳士得保留不時更改高額拍賣品登記程序及要求的權利而不作另行通知。

請提供閣下之競投總額：

- 港幣 0 - 500,000 港幣 500,001 - 2,000,000 港幣 2,000,001 - 4,000,000
- 港幣 4,000,001 - 8,000,000 港幣 8,000,001 - 20,000,000 港幣 20,000,000 +

C 拍賣項目登記

本人有意競投下列拍賣項目：

- 12576 佳士得名釀 12578 精緻名錶
- 12577 佳士得名釀 12561 中國古代書畫
- 14617 先鋒薈萃 12562 中國近現代畫
- 12520 亞洲二十世紀及當代藝術 (晚間拍賣) 12579 瑰麗珠寶及翡翠首飾
- 12521 亞洲當代藝術 (日間拍賣) 12675 養德堂珍藏中國古陶瓷器
- 12523 亞洲二十世紀藝術 (日間拍賣) 12587 典雅傳承：手袋及配件
- 12560 中國當代水墨 12563 重要中國瓷器及工藝精品

D 提貨及運送安排

請選擇下列提貨及運送安排：

- 本人將親自提取已繳付之拍賣品。
- 請按本人之客戶地址 / 以下地址提供貨運報價。

E 聲明

- 本人已細閱載於目錄內之業務規定，買家須知、重要通告及目錄編列方法之說明及不接受第三方付款通告，並同意遵守所有規定。
- 本人已細閱載於目錄內業務規定之資料搜集條款，並同意遵守該規定。
- 拍賣官僅接受已於拍賣日前繳付保證金並已完成高額拍賣品預先登記人士之高額拍賣品競投。本人知悉若本人未於拍賣前完成高額拍賣預先登記，本人將不獲准競投高額拍賣品。
- 若閣下未能成功競投任何拍賣品，對佳士得或佳士得公司集團亦無任何欠款，保證金將以電匯方式或佳士得決定之其他方式退還閣下。請確保閣下已提供有關之銀行資料詳情。
- 如閣下為新客戶並希望透過電郵接收本公司將舉行的拍賣、活動或其他由佳士得集團及其聯營公司提供的服務資料，請於方格內劃上「✓」號。閣下可隨時選擇拒收此訊息。
- 如閣下選擇不以電郵方式收取發票，請於方格內劃上「✓」號。

姓名 簽署 日期

佳士得香港有限公司

香港中環遮打道 18 號歷山大廈 22 樓 電話：+852 2760 1766

www.christies.com



CHRISTIE'S

CHRISTIE'S INTERNATIONAL PLC

Patricia Barbizet, Chairwoman and CEO
Jussi Pylkkänen, Global President
Stephen Brooks, Deputy CEO
Loïc Brivezac, Gilles Erulin, Gilles Pagniez,
Héloïse Temple-Boyer
Sophie Carter, Company Secretary

CHRISTIE'S EXECUTIVE

Patricia Barbizet, Chairwoman and CEO
Jussi Pylkkänen, Global President
Stephen Brooks, Deputy CEO

INTERNATIONAL CHAIRMEN

François Curiel, Chairman, Asia Pacific
Stephen Lash, Chairman, Emeritus, Americas
Viscount Linley, Honorary Chairman, EMERI
Charles Cator, Deputy Chairman, Christie's Int.
Xin Li, Deputy Chairwoman, Christie's Int.

CHRISTIE'S ASIA PACIFIC

François Curiel, Chairman
Xin Li, Deputy Chairwoman

CHRISTIE'S ASIA

Rebecca Wei, President
Jinqing Cai, Chairwoman, China
Jonathan Stone, Chairman, Asian Art

CHAIRMAN'S OFFICE

Eric Chang, Deputy Chairman
Ben Kong, Deputy Chairman
Vickie Sek, Deputy Chairwoman

SENIOR VICE PRESIDENTS

Pola Antebi, Karen Au Yeung, Lavina Chan,
Salene Chan, YF Cheung, Elaine Holt,
Kitty Mak, Ada Ong, Julien Pradel,
Audrey Shum, Simon Tam, Chi Fan Tsang

VICE PRESIDENTS

Hye-Kyung Bae, Chie Banta, Joyce Chan,
Janet Chang, Blanca Cheng, Charmie Hamami,
Gloria Ho, Julia Hu, Pansy Ku,
Marcello Kwan, Elaine Kwok, Mary Lee,
Stephenie Leung, Ruben Lien, Gabrielle Mak,
Lillian Ng, Jasmin Ngai, Patricia Nobel,
Gen Ogo, Jessie Or, Terence Poon,
Bo Tan, Francis Tsang, Tim Triptree,
Lihua Tung, Nicole Wright, Alan Yip,
Kim Yu

ASSOCIATE VICE PRESIDENTS

Hami Bianchi, Carmen Shek Cerne, Jess Chang,
Lesley Chen, Liang-Lin Chen, Amy Cheng,
Shiu-Fung Chiang, Isaac Choi, Terry Choi,
Dai Dai, Aubrey Daval, Phybie Ho,
Dexter How, Yunah Jung, Bigol Lam,
Keyvn Leung, Danqing Li, Nelly Li,
Rachel Li, May Lim, Meng Hong Lim,
Georgina Liu, Sara Mao, Mami Nagase,
Yaovane Nirandara, Benson Or, Felix Pei,
Punchalee Phenjati, Alexandra Reid, Mandy Wang,
Stella Wang, Michael Xie, Jessica Wu,
Wendy Xu, Austin Zhang, Dina Zhang,
Michelle Zhang, Grace Zhuang

CHRISTIE'S ASIA ADVISORY COUNCIL

Rebecca Wei, Chairwoman
Raymond CH'ien, Pierre Chen,
The Baroness Dunn, William Fung,
Joyce Kan, Anthony Lin,
Dee Poon, Mimi Tang,
Robert Tsao, Douglas Woo

CHRISTIE'S CHINA ADVISORY COUNCIL

Jinqing Cai, Chairwoman
Qionger Jiang, Pan Gong Kai, Handel Lee,
Mary Ma, Patrick Thomas, Wang Wei

06/10/16

HONG KONG AUCTION CALENDAR

FINE AND RARE WINES: A GENTLEMAN'S COLLECTION

Sale number: 12576
FRIDAY 25 NOVEMBER
5.00 PM
SATURDAY 26 NOVEMBER
10.30 AM

FINE AND RARE WINES FEATURING EXCEPTIONAL PRIVATE COLLECTIONS

Sale number: 12577
SATURDAY 26 NOVEMBER
1.00 PM

THE PIONEERS

Sale number: 14617
SATURDAY 26 NOVEMBER
6.30 PM
Viewing: 24-26 November

ASIAN 20TH CENTURY & CONTEMPORARY ART (EVENING SALE)

Sale number: 12520
SATURDAY 26 NOVEMBER
7.00 PM
Viewing: 24-26 November

ASIAN CONTEMPORARY ART (DAY SALE)

Sale number: 12521
SUNDAY 27 NOVEMBER
10.30 AM
Viewing: 24-26 November

ASIAN 20TH CENTURY ART (DAY SALE)

Sale number: 12523
SUNDAY 27 NOVEMBER
1.30 PM
Viewing: 24-26 November

CHINESE CONTEMPORARY INK

Sale number: 12560
MONDAY 28 NOVEMBER
11.00 AM
Viewing: 24-27 November

IMPORTANT WATCHES

Sale number: 12578
MONDAY 28 NOVEMBER
12.00 PM
Viewing: 24-27 November

FINE CHINESE CLASSICAL PAINTINGS AND CALLIGRAPHY

Sale number: 12561
MONDAY 28 NOVEMBER
2.30 PM
Viewing: 24-28 November

FINE CHINESE MODERN PAINTINGS

Sale number: 12562
TUESDAY 29 NOVEMBER
10.00 AM & 2.30 PM
Viewing: 24-28 November

HONG KONG MAGNIFICENT JEWELS

Sale number: 12579
TUESDAY 29 NOVEMBER
1.00 PM
Viewing: 24-29 November

CHINESE CERAMICS FROM THE YANGDETANG COLLECTION

Sale number: 12675
WEDNESDAY 30 NOVEMBER
10.30 AM
Viewing: 24-29 November

HANDBAGS & ACCESSORIES

Sale number: 12587
WEDNESDAY 30 NOVEMBER
11.00 AM
Viewing: 24-29 November

IMPORTANT CHINESE CERAMICS AND WORKS OF ART

Sale number: 12563
WEDNESDAY 30 NOVEMBER
11.30 AM & 2.30 PM
Viewing: 24-29 November





GRAND VIN
DE
CHATEAU LATOUR

1861

MIS EN BOUTEILLES
AU CHATEAU

APPELLATION D'ORIGINE CONTRÔLÉE



GRAND VIN
DE
CHATEAU LATOUR

1858

CHRISTIE'S 佳士得

22ND FLOOR ALEXANDRA HOUSE 18 CHATER ROAD CENTRAL HONG KONG
香港 中環 遮打道18號 歷山大廈22樓